

General Turning Toolholders

Selection Guide	E02
Holder Identification System	E03
Structures and Features of NTK Toolholders for General Turning	E04
For CN..Inserts	E05
For DN..Inserts	E14
For SN..Inserts	E21
For VN..Inserts	E32
For TN..Inserts	E36
For WN..Inserts	E45
For RN..Inserts	E47
For CDH..Inserts	E51
For RCGX/RPGX..Inserts	E52
For RCGY..Inserts	E57
For TSN..Inserts	E58

Selection Guide

Lead Angle (KAPR)		95°	75° (Using 100° Corner)	75°	60°	75°	91°	91°
Tooling								
Insert shape		CNGN/CNGX/CNGA 	CNGN/CNGA 		TNGN/TNGA 			
Perfect for Ceramic Insert	Multi Clamp	WCLN/TCLN/HCLN →E5	WCBN/TCBN →E7				WTGN/TTGN →E36	WTFN/TTFN →E36
	Clamp On	CCLN/C31 →E5,E7	CCBN →E8	CCKN →E8	C24 →E39	C23 →E39	C21/C22 →E37	C25 →E38
For Insert in General	Lever Lock	PCLN →E6						
Lead Angle (KAPR)		60°	75°	75°	85°	85°	45°	45°
Tooling								
Insert shape		SNGA/SNGN 				SNGA/SNGX/SNGN 		
Perfect for Ceramic Insert	Multi Clamp						WSSN/TSSN/HSSN →E21	WSDN/TSDN/HSDN →E21
	Clamp On	C13 →E24	C15 →E25	C11/C16 →E25,E26	C17 →E26	CSHN →E27	CSSN/C12 →E22,E23	CSDN/C14 →E22,E23
For Insert in General	Lever Lock			PSBN →E24				PSDN →E22
Lead Angle (KAPR)		93°	107°30'	62°30'	93°	117°30'	72°30'	95°
Tooling								
Insert shape		DNGA/DNGX 		VNGA/VNGX 		WNGA 		
Perfect for Ceramic Insert	Multi Clamp	WDJN/HDJN →E14	WDHN/HDHN →E15	WDNN/HDNN →E16	WVJN/HVJN →E32	WVPN/HVPN →E32	WVNN/HVNN →E33	WWLN/WWLN-2 →E45
	Clamp On							
For Insert in General	Lever Lock	PDJN →E15						
Lead Angle (KAPR)		-	-	-	-	-	-	-
Tooling								
Insert shape		RGN 	RCGY 	RCGX/RPGX 	CDH 	TSN 		
Perfect for Ceramic Insert	Multi Clamp	CRDNN/C54 →E47,E48	CRGN/C55 →E47,E48	CRXC →E57	CRDCN →E52	HN..ATS/BTS →E58		
	Clamp On					HRCD →E51		
	Blade				GTWP →E53 GKWP →E54			

Holder Identification System

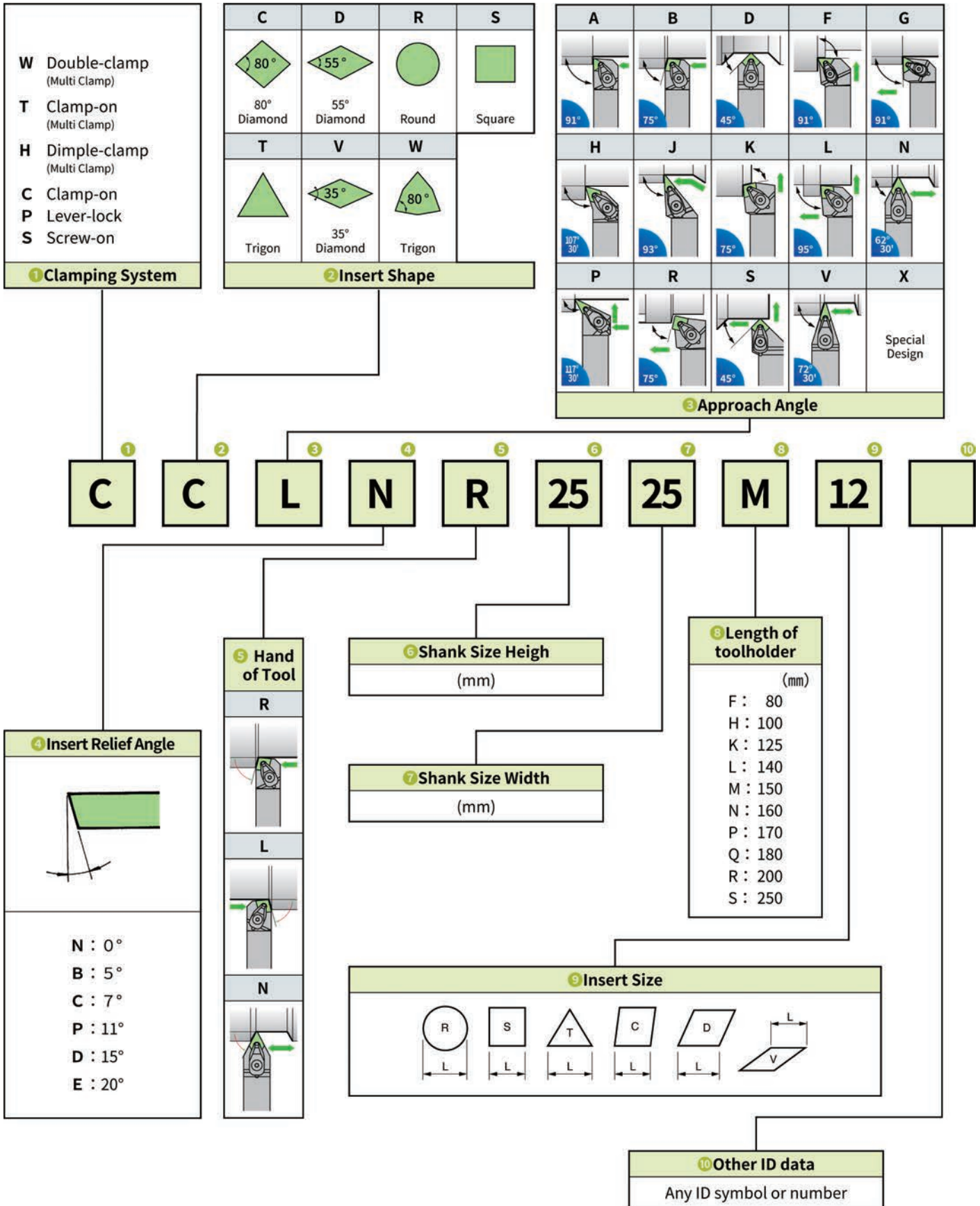

Parts and Features of NTK Toolholders for General Turning

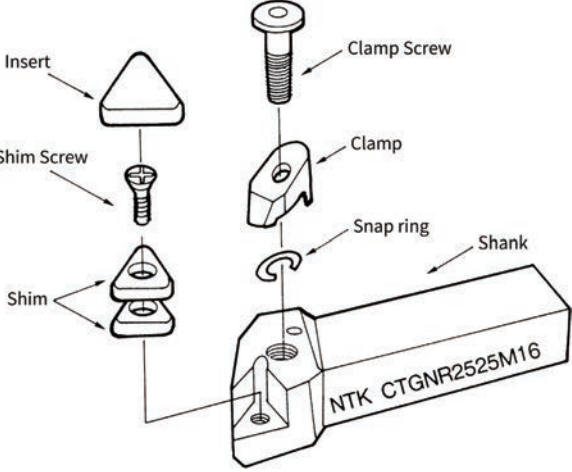
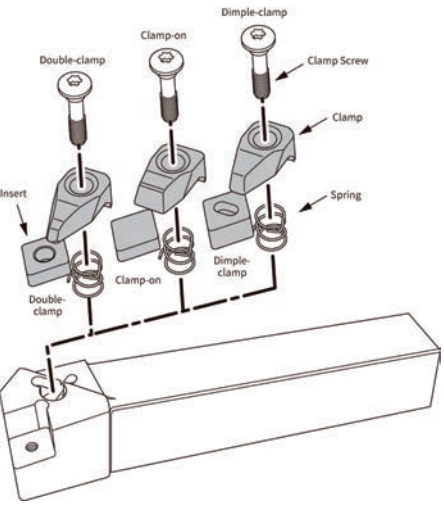
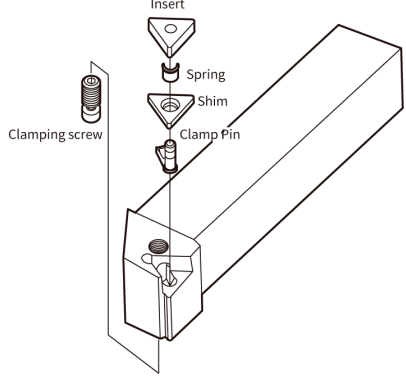
Series	Parts	Features
C type : Clamp-on		<ul style="list-style-type: none"> • Secures the insert with high clamping force • Excellent in indexing accuracy • Suitable for heavy-duty applications including interrupted cut machining • Clamping system for ceramic cutting tools
W type : Double-clamp	<div style="text-align: center; background-color: red; color: white; padding: 5px; border-radius: 10px; display: inline-block;">Multi-clamp holder</div> 	<ul style="list-style-type: none"> • Shim screw clamping methods can be utilized by a simple clamp shim • Best for ceramic tools, improved system with stronger and more accurate clamping • Prevents insert breakage by optimizing the clamping force • Allows for highly accurate machining with highly repeatable accuracy • Inserts can be easily changed as clamping is possible from the top and bottom of the tool • Recommended Tightening Torque For LLR-T20 3.0Nm : Double-clamp 7.5Nm : Clamp-on, Dimple-clamp For LLR-T15 5.0Nm
T type : Clamp-on		
H type : Dimple-clamp		
P type : Lever lock		<ul style="list-style-type: none"> • General-purpose toolholder • Allows for smooth chip control without damaging the clamping mechanism • For inserts of all material grades however not recommended for ceramics

CN..series/Toolholders

WCLN/TCLN/HCLN Multi Clamp Toolholders

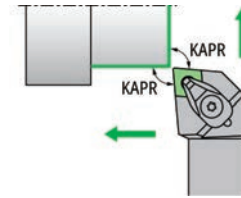
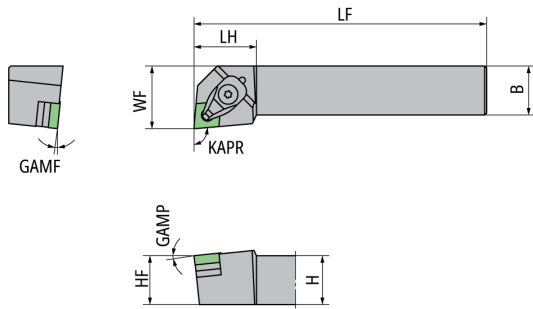

● Diagram shows right-hand tool

EDP	Item Number	Stock	Hand	B mm	GAMF °	GMAP °	H mm	HF mm	KAPR °	LF mm	LH mm	WF mm	Insert Gage
5682570	WCLNR2525M12	●	R	25	6	6	25	25	95	150	32	32	CN..1204.. (CN..1207..)
5682604	WCLNR3225P12	●	R	25	6	6	32	32	95	170	32	32	CN..1204.. (CN..1207..)
5682588	WCLNL2525M12	●	L	25	6	6	25	25	95	150	32	32	CN..1204.. (CN..1207..)
5682612	WCLNL3225P12	●	L	25	6	6	32	32	95	170	32	32	CN..1204.. (CN..1207..)
5701610	TCLNR2525M12	●	R	25	6	6	25	25	95	150	32	32	CN..1204.. (CN..1207..)
5701131	TCLNR3225P12	●	R	25	6	6	32	32	95	170	32	32	CN..1204.. (CN..1207..)
5701628	TCLNL2525M12	●	L	25	6	6	25	25	95	150	32	32	CN..1204.. (CN..1207..)
5701636	TCLNL3225P12	●	L	25	6	6	32	32	95	170	32	32	CN..1204.. (CN..1207..)
5701149	HCLNR2525M12	●	R	25	6	6	25	25	95	150	32	32	CNGX1207.. -
5701875	HCLNR3225P12	●	R	25	6	6	32	32	95	170	32	32	CNGX1207.. -
5701156	HCLNL2525M12	●	L	25	6	6	25	25	95	150	32	32	CNGX1207.. -
5701883	HCLNL3225P12	●	L	25	6	6	32	32	95	170	32	32	CNGX1207.. -

General Turning
Toolholders

Spare Parts

Item Number	Clamp	Shim	Clamp screw	Screw (for Shim)	Wrench (for Clamp screw)	Wrench (for Shim)	Spring
WCLNR2525M12	DC6CN	ACN423	AOS-6*30W	FSS15-3.0*12	LLR-T20	LLR-T10	ASGL6-D
WCLNR3225P12	DC6CN	ACN423	AOS-6*30W	FSS15-3.0*12	LLR-T20	LLR-T10	ASGL6-D
WCLNL2525M12	DC6CN	ACN423	AOS-6*30W	FSS15-3.0*12	LLR-T20	LLR-T10	ASGL6-D
WCLNL3225P12	DC6CN	ACN423	AOS-6*30W	FSS15-3.0*12	LLR-T20	LLR-T10	ASGL6-D
TCLNR2525M12	TC6CN	ACN423	AOS-6*30W	FSS15-3.0*12	LLR-T20	LLR-T10	ASGL6-D
TCLNR3225P12	TC6CN	ACN423	AOS-6*30W	FSS15-3.0*12	LLR-T20	LLR-T10	ASGL6-D
TCLNL2525M12	TC6CN	ACN423	AOS-6*30W	FSS15-3.0*12	LLR-T20	LLR-T10	ASGL6-D
TCLNL3225P12	TC6CN	ACN423	AOS-6*30W	FSS15-3.0*12	LLR-T20	LLR-T10	ASGL6-D
HCLNR2525M12	HC6CN	ACN423	AOS-6*30W	FSS15-3.0*12	LLR-T20	LLR-T10	ASGL6-D
HCLNR3225P12	HC6CN	ACN423	AOS-6*30W	FSS15-3.0*12	LLR-T20	LLR-T10	ASGL6-D
HCLNL2525M12	HC6CN	ACN423	AOS-6*30W	FSS15-3.0*12	LLR-T20	LLR-T10	ASGL6-D
HCLNL3225P12	HC6CN	ACN423	AOS-6*30W	FSS15-3.0*12	LLR-T20	LLR-T10	ASGL6-D

CCLN

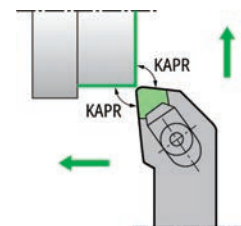
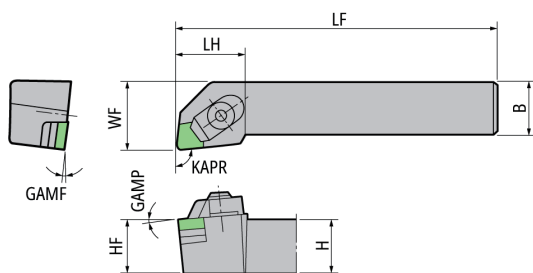

● Diagram shows right-hand tool

EDP	Item Number	Stock	Hand	B mm	GAMF °	GMAP °	H mm	HF mm	KAPR °	LF mm	LH mm	WF mm	Insert Gage
5700315	CCLNR3225P12	●	R	25	6	6	32	32	95	170	32	32	CN..1204.. (CN..1207..)
5700299	CCLNL3225P12	●	L	25	6	6	32	32	95	170	32	32	CN..1204.. (CN..1207..)

Spare Parts

Item Number	Clamp	Shim	Clamp screw	Screw (for Shim)	Wrench (for Clamp screw)	Snap
CCLNR3225P12	CC08M	ACN422	BS0835W	M3*12	LW-4	SR08
CCLNL3225P12	CC08M	ACN422	BS0835W	M3*12	LW-4	SR08

PCLN-N

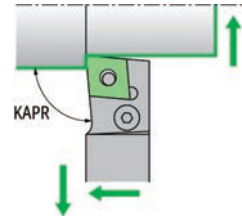
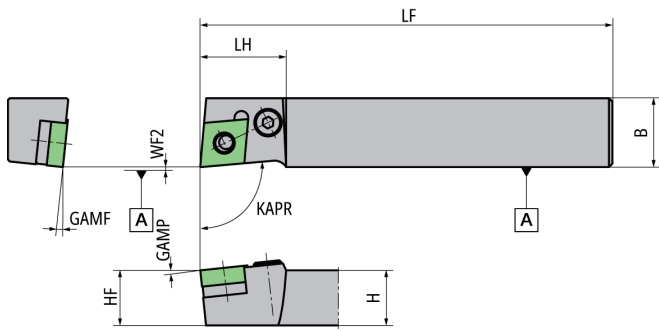

● Diagram shows right-hand tool

EDP	Item Number	Stock	Hand	B mm	GAMF °	GMAP °	H mm	HF mm	KAPR °	LF mm	LH mm	WF2 mm	Insert Gage
5259056	PCLNR1620X43N	●	R	20	6	6	16	16	95	120	25	0	CN..1204..

Spare Parts

Item Number	Shim	Clamp screw	Wrench (for Clamp screw)	Clamp Pin	Spring
PCLNR1620X43N	LSC42	LCS4CA	LW-3	LCL4	LSP4

PCLN

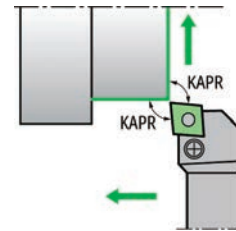
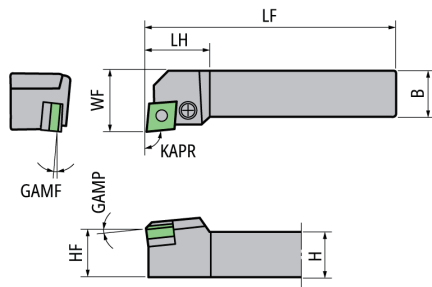

● Diagram shows right-hand tool

EDP	Item Number	Stock	Hand	B mm	GAMF °	GMAP °	H mm	HF mm	KAPR °	LF mm	LH mm	WF mm	Insert Gage
5321997	PCLNR2020K43	●	R	20	6	6	20	20	95	125	28	25	CN..1204..
5322011	PCLNR2525M43	●	R	25	6	6	25	25	95	150	28	32	CN..1204..
5322003	PCLNL2020K43	●	L	20	6	6	20	20	95	125	28	25	CN..1204..
5322029	PCLNL2525M43	●	L	25	6	6	25	25	95	150	28	32	CN..1204..

Spare Parts

Item Number	Clamp	Shim	Clamp screw	Wrench (for Clamp screw)	Clamp Pin	Spring
PCLNR2020K43	-	LSC42	LCS4	LW-3	LCL4	LSP4
PCLNR2525M43	-	LSC42	LCS4	LW-3	LCL4	LSP4
PCLNL2020K43	-	LSC42	LCS4	LW-3	LCL4	LSP4
PCLNL2525M43	-	LSC42	LCS4	LW-3	LCL4	LSP4

C31

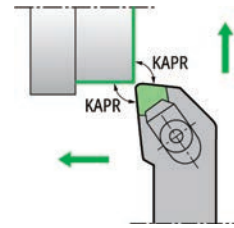
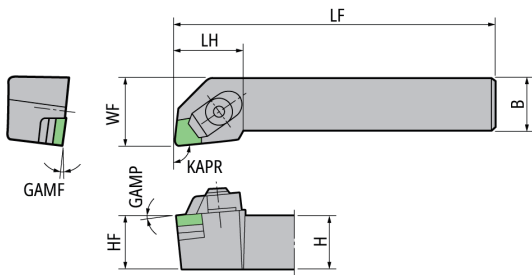

● Diagram shows right-hand tool

EDP	Item Number	Stock	Hand	B mm	GAMF °	GMAP °	H mm	HF mm	KAPR °	LF mm	LH mm	WF mm	Insert Gage	
5538301	C31R-44	●	R	25	6	6	25	25	95	160	32	32	CN..1204..	(CN..1207..)
5601422	C31R-45	●	R	25	6	6	32	32	95	160	32	32	CN..1204..	(CN..1207..)
5538293	C31L-33	●	L	19	6	6	19	19	95	140	32	25	CN..1204..	-
5538319	C31L-44	●	L	25	6	6	25	25	95	160	32	32	CN..1204..	(CN..1207..)
5601430	C31L-45	●	L	25	6	6	32	32	95	160	32	32	CN..1204..	(CN..1207..)

Spare Parts

Item Number	Clamp	Shim	Clamp screw	Screw (for Clamp)	Wrench (for Shim)	Snap
C31R-44	CC08M	ACN422	BS0835W	M3*12	LW-4	SR08
C31R-45	CC08M	ACN422	BS0835W	M3*12	LW-4	SR08
C31L-33	CC08M	ACN422	BS0829W	M3*12	LW-4	SR08
C31L-44	CC08M	ACN422	BS0835W	M3*12	LW-4	SR08
C31L-45	CC08M	ACN422	BS0835W	M3*12	LW-4	SR08

WCBN/TCBN Multi Clamp Toolholders

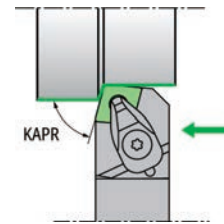
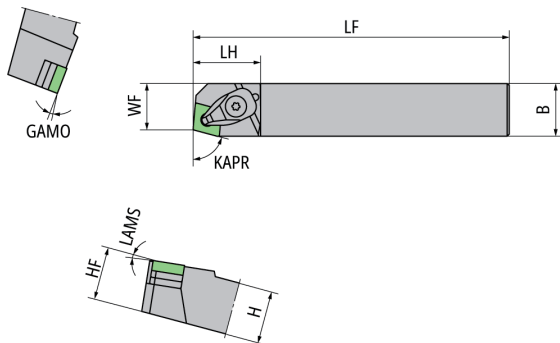

● Diagram shows right-hand tool

EDP	Item Number	Stock	Hand	B mm	GAMO °	H mm	HF mm	KAPR °	LAMS °	LF mm	LH mm	WF mm	Insert Gage	
5682620	WCBNR2525M12	●	R	25	6	25	25	75	6	150	32	22	CN..1204..	(CN..1207..)
5682638	WCBNL2525M12	●	L	25	6	25	25	75	6	150	32	22	CN..1204..	(CN..1207..)
5701644	TCBNR2525M12	●	R	25	6	25	25	75	6	150	32	22	CN..1204..	(CN..1207..)
5701651	TCBNL2525M12	●	L	25	6	25	25	75	6	150	32	22	CN..1204..	(CN..1207..)

Spare Parts

Item Number	Clamp	Shim	Clamp screw	Screw (for Shim)	Wrench (for Clamp screw)	Wrench (for Shim)
WCBNR2525M12	DC6CN	ACN423	AOS-6*30W	FSS15-3.0*12	LLR-T20	LLR-T10
WCBNL2525M12	DC6CN	ACN423	AOS-6*30W	FSS15-3.0*12	LLR-T20	LLR-T10
TCBNR2525M12	TC6CN	ACN423	AOS-6*30W	FSS15-3.0*12	LLR-T20	LLR-T10
TCBNL2525M12	TC6CN	ACN423	AOS-6*30W	FSS15-3.0*12	LLR-T20	LLR-T10

CCBN

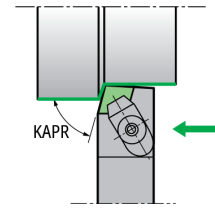
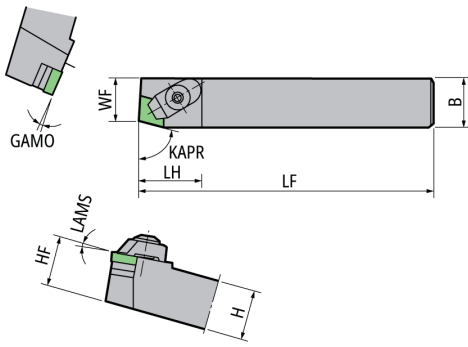

● Diagram shows right-hand tool

EDP	Item Number	Stock	Hand	B mm	GAMO °	H mm	HF mm	KAPR °	LAMS °	LF mm	LH mm	WF mm	Insert Gage
5830617	CCBNR2525M12	●	R	25	6	25	25	75	6	150	32	22	CN..1204.. (CN..1207..)

Spare Parts

Item Number	Clamp	Shim	Clamp screw	Screw (for Shim)	Wrench (for Clamp screw)	Snap
CCBNR2525M12	CC08M	ACN422	BS0835W	M3*12	LW-4	SR08

CCKN

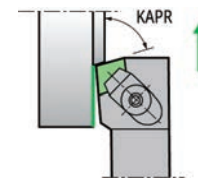
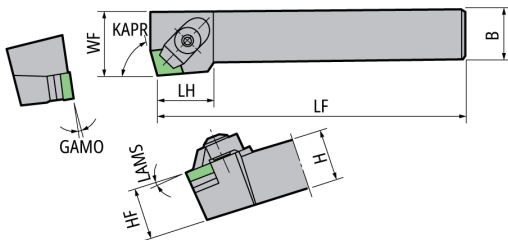

● Diagram shows right-hand tool

EDP	Item Number	Stock	Hand	B mm	GAMO °	H mm	HF mm	KAPR °	LAMS °	LF mm	LH mm	WF mm	Insert Gage
5613690	CCKNR2525M12	●	R	25	6	25	25	75	6	150	30	32	CN..1204.. (CN..1207..)

Spare Parts

Item Number	Clamp	Shim	Clamp screw	Screw (for Shim)	Wrench (for Clamp screw)	Snap
CCKNR2525M12	CC08M	ACN422	BS0835W	M3*12	LW-4	SR08

CN.. series/Inserts CBN

CNGA

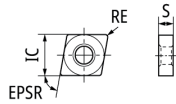

Steel	
Stainless Steel	
Cast Iron	● ● ● ● ○ ○
Non-Ferrous Material	
Heat Resistant Alloy	
Hardened Material	● ● ● ● ●
Others (non-metallic)	

Shape	Item Number (ISO)	CECC	EPSR °	IC mm	S mm	AN °	RE mm	D2 mm	Length of edge	No. of edge	S1 mm	CBN										
												B16 PVD	B22	B23	B30	B36	B6K PVD	B40	B52	B5K PVD		
	CNGA120402PQS01015	S01015	80	12.7	4.76	-	0.2	-	2.3	4	-											
	CNGA120402PQS01325	S01325	80	12.7	4.76	-	0.2	-	2.3	4	-											
	CNGA120402PQS01535	S01535	80	12.7	4.76	-	0.2	-	2.3	4	-											
	CNGA120402PQT01020	T01020	80	12.7	4.76	-	0.2	-	2.3	4	-											
	CNGA120404PDFNX	Up-sharp edge	80	12.7	4.76	-	0.4	-	2.3	2	-											
	CNGA120404PQFNX	Up-sharp edge	80	12.7	4.76	-	0.4	-	2.3	4	-											
	CNGA120404PQS01015	S01015	80	12.7	4.76	-	0.4	-	2.3	4	-											
	CNGA120404PQS01020	S01020	80	12.7	4.76	-	0.4	-	2.3	4	-											
	CNGA120404PQS01325	S01325	80	12.7	4.76	-	0.4	-	2.3	4	-											
	CNGA120404PQS01535	S01535	80	12.7	4.76	-	0.4	-	2.3	4	-											
	CNGA120404PQT01020	T01020	80	12.7	4.76	-	0.4	-	2.3	4	-											
	CNGA120408PDFNX	Up-sharp edge	80	12.7	4.76	-	0.8	-	2.2	2	-											
	CNGA120408PQFNX	Up-sharp edge	80	12.7	4.76	-	0.8	-	2.2	4	-											
	CNGA120408PQS01015	S01015	80	12.7	4.76	-	0.8	-	2.2	4	-											
	CNGA120408PQS01020	S01020	80	12.7	4.76	-	0.8	-	2.2	4	-											
	CNGA120408PQS01325	S01325	80	12.7	4.76	-	0.8	-	2.2	4	-											
	CNGA120408PQS01535	S01535	80	12.7	4.76	-	0.8	-	2.2	4	-											
	CNGA120408PQT00515	T00515	80	12.7	4.76	-	0.8	-	2.2	4	-											
	CNGA120408PQT01020	T01020	80	12.7	4.76	-	0.8	-	2.2	4	-											
	CNGA120412PDFNX	Up-sharp edge	80	12.7	4.76	-	1.2	-	2.7	2	-											
	CNGA120412PQFNX	Up-sharp edge	80	12.7	4.76	-	1.2	-	2.7	4	-											
	CNGA120412PQS01015	S01015	80	12.7	4.76	-	1.2	-	2.7	4	-											
	CNGA120412PQS01020	S01020	80	12.7	4.76	-	1.2	-	2.7	4	-											
	CNGA120412PQS01325	S01325	80	12.7	4.76	-	1.2	-	2.7	4	-											
	CNGA120412PQS01535	S01535	80	12.7	4.76	-	1.2	-	2.7	4	-											
	CNGA120412PQT00515	T00515	80	12.7	4.76	-	1.2	-	2.7	4	-											
	CNGA120412PQT01020	T01020	80	12.7	4.76	-	1.2	-	2.7	4	-											
	CNGA120416PQS01015	S01015	80	12.7	4.76	-	1.6	-	2.6	4	-											
	CNGA120416PQS01020	S01020	80	12.7	4.76	-	1.6	-	2.6	4	-											
	CNGA120416PQS01325	S01325	80	12.7	4.76	-	1.6	-	2.6	4	-											
	CNGA120416PQS01535	S01535	80	12.7	4.76	-	1.6	-	2.6	4	-											
	CNGA120416PQT01020	T01020	80	12.7	4.76	-	1.6	-	2.6	4	-											
	CNGA120420PQS01015	S01015	80	12.7	4.76	-	2	-	2.6	4	-											
	CNGA120420PQS01020	S01020	80	12.7	4.76	-	2	-	2.6	4	-											
	CNGA120420PQS01325	S01325	80	12.7	4.76	-	2	-	2.6	4	-											
	CNGA120420PQS01535	S01535	80	12.7	4.76	-	2	-	2.6	4	-											
	CNGA120420PQT01020	T01020	80	12.7	4.76	-	2	-	2.6	4	-											

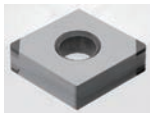

General Turning
Toolholders
U1

CNGA-W with wiper for higher feed

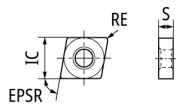

Steel	
Stainless Steel	
Cast Iron	● ● ● ● ○ ○
Non-Ferrous Material	
Heat Resistant Alloy	
Hardened Material	● ● ● ● ●
Others (non-metallic)	

Shape	Item Number (ISO)	CECC	EPSR °	IC mm	S mm	AN °	RE mm	D2 mm	Length of edge	No. of edge	S1 mm	CBN										
												B16 PVD	B22	B23	B30	B36	B6K PVD	B40	B52	B5K PVD		
	CNGA120404PQWS01015	S01015	80	12.7	4.76	-	0.4	-	2.3	4	-											
	CNGA120404PQWS01535	S01535	80	12.7	4.76	-	0.4	-	2.3	4	-											
	CNGA120408PQWS01015	S01015	80	12.7	4.76	-	0.8	-	2.2	4	-											
	CNGA120408PQWS01535	S01535	80	12.7	4.76	-	0.8	-	2.2	4	-											
	CNGA120412PQWS01015	S01015	80	12.7	4.76	-	1.2	-	2.7	4	-											
	CNGA120412PQWS01535	S01535	80	12.7	4.76	-	1.2	-	2.7	4	-											

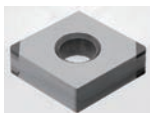

Wiper Width: 0.25mm

Applicable holders: 95°cutting edge angle (C31, CCLN).

CN.. series/Inserts PCD / Diamond Coating

CNM.

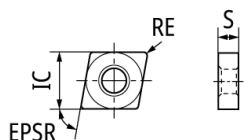

Steel										
Stainless Steel										
Cast Iron										
Non-Ferrous Material	●	●	●							
Heat Resistant Alloy										
Hardened Material										
Others (non-metallic)										●

Shape	Item Number (ISO)	CECC	EPSR °	IC mm	S mm	AN °	RE mm	No. of edge	PCD		Diamond Coating
									PD1	PD2	UC1
	CNMG120404FNZP	Up-sharp edge	80	12.7	4.76	-	0.4	4			●
	CNMG120408FNZP	Up-sharp edge	80	12.7	4.76	-	0.8	4			●
	CNMX120404PF	Up-sharp edge	80	12.7	4.76	-	0.4	1		●	
	CNMX120408PF	Up-sharp edge	80	12.7	4.76	-	0.8	1		●	

CN.. series/Inserts Carbide

CN..

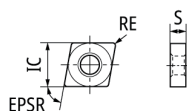

Steel	○	●	●	●	●	●	●	●	●	●
Stainless Steel	●	○	○	○	●	○	●	●	●	●
Cast Iron										●
Non-Ferrous Material								○	○	●
Heat Resistant Alloy		●	○	○						
Hardened Material		○	○	○						
Others (non-metallic)										●

Shape	Item Number (ISO)	CECC	EPSR °	IC mm	S mm	AN °	RE mm	BS mm	Carbide										
									PVD ST4	PVD DM4	PVD DT4	PVD QM3	PVD TM4	PVD VM1	PVD ZM3	CVD CP1	CVD CP7	Uncoated KM1	
	CNGG120404FNUL	Up-sharp edge	80	12.7	4.76	-	0.4	-		●	●	●							
	CNGG120408FNUL	Up-sharp edge	80	12.7	4.76	-	0.8	-		●	●	●							
	CNGG120404FNZP	Up-sharp edge	80	12.7	4.76	-	0.4	-		●	●				●				
	CNGG120408FNZP	Up-sharp edge	80	12.7	4.76	-	0.8	-		●	●				●				
	CNMG120408T00525Z5	T00525	80	12.7	4.76	-	0.8	-		●	●								
	CNMG120408G	-	80	12.7	4.76	-	0.8	-											●
	CNMG120412G	-	80	12.7	4.76	-	1.2	-											●
	CNMG120416G	-	80	12.7	4.76	-	1.6	-											●

General Turning Toolholders

DN.. series/Toolholders

WDJN/HDJN Multi Clamp Toolholders

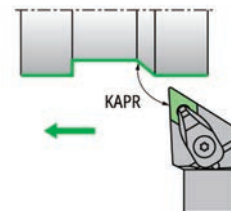
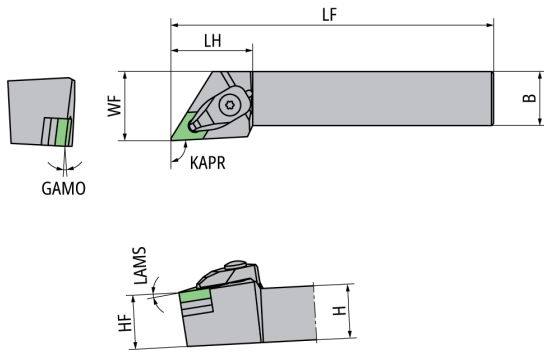

● Diagram shows right-hand tool

EDP	Item Number	Stock	Hand	B mm	GAMO °	H mm	HF mm	KAPR °	LAMS °	LF mm	LH mm	WF mm	Insert Gage
5682729	WDJNR2525M15	●	R	25	6	25	25	93	6	150	38	32	DN..1504.. (DN..1507..)
5682745	WDJNR3225P15	●	R	25	6	32	32	93	6	170	38	32	DN..1504.. (DN..1507..)
5682737	WDJNL2525M15	●	L	25	6	25	25	93	6	150	38	32	DN..1504.. (DN..1507..)
5682752	WDJNL3225P15	●	L	25	6	32	32	93	6	170	38	32	DN..1504.. (DN..1507..)
5701263	HDJNR2525M15	●	R	25	6	25	25	93	6	150	38	32	DNGX1507.. -
5701289	HDJNR3225P15	●	R	25	6	32	32	93	6	170	38	32	DNGX1507.. -
5701271	HDJNL2525M15	●	L	25	6	25	25	93	6	150	38	32	DNGX1507.. -
5701297	HDJNL3225P15	●	L	25	6	32	32	93	6	170	38	32	DNGX1507.. -

Spare Parts

Item Number	Clamp	Shim	Clamp screw	Screw (for shim)	Wrench (for Clamp screw)	Wrench (for shim)	Spring
WDJNR2525M15	DC6DN	ADN423	AOS-6*30W	FSS15-3.0*12	LLR-T20	LLR-T10	ASGL6-D
WDJNR3225P15	DC6DN	ADN423	AOS-6*30W	FSS15-3.0*12	LLR-T20	LLR-T10	ASGL6-D
WDJNL2525M15	DC6DN	ADN423	AOS-6*30W	FSS15-3.0*12	LLR-T20	LLR-T10	ASGL6-D
WDJNL3225P15	DC6DN	ADN423	AOS-6*30W	FSS15-3.0*12	LLR-T20	LLR-T10	ASGL6-D
HDJNR2525M15	HC6DN	ADN423	AOS-6*30W	FSS15-3.0*12	LLR-T20	LLR-T10	ASGL6-D
HDJNR3225P15	HC6DN	ADN423	AOS-6*30W	FSS15-3.0*12	LLR-T20	LLR-T10	ASGL6-D
HDJNL2525M15	HC6DN	ADN423	AOS-6*30W	FSS15-3.0*12	LLR-T20	LLR-T10	ASGL6-D
HDJNL3225P15	HC6DN	ADN423	AOS-6*30W	FSS15-3.0*12	LLR-T20	LLR-T10	ASGL6-D

PDJN-N

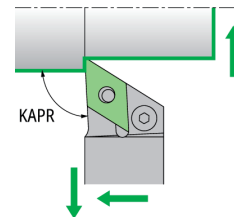
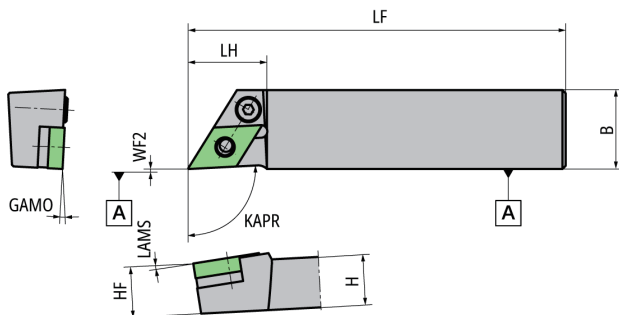

● Diagram shows right-hand tool

EDP	Item Number	Stock	Hand	B mm	GAMO °	H mm	HF mm	KAPR °	LAMS °	LF mm	LH mm	WF2 mm	Insert Gage
5259072	PDJNR1625X43N	●	R	25	6	16	16	93	6	120	25	0	DN..1504..

Spare Parts

Item Number	Shim	Clamp screw	Wrench (for Clamp)	Clamp Pin	Spring
PDJNR1625X43N	LSD42	LCS4CA	LW-3	LCL4	LSP4

PDJN

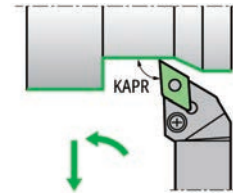
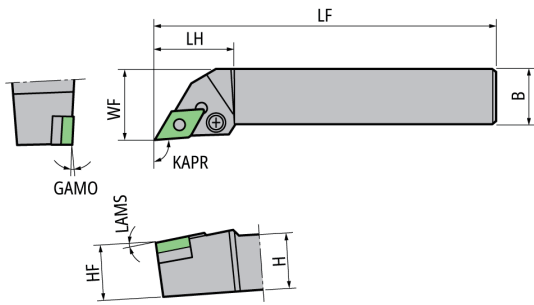

● Diagram shows right-hand tool

EDP	Item Number	Stock	Hand	B mm	GAMO °	H mm	HF mm	KAPR °	LAMS °	LF mm	LH mm	WF mm	Insert Gage
5322037	PDJNR2020K43	●	R	20	6	20	20	93	6	125	32	25	DN..1504..
5682463	PDJNR2525M43	●	R	25	6	25	25	93	6	150	32	32	DN..1504..
5322045	PDJNL2020K43	●	L	20	6	20	20	93	6	125	32	25	DN..1504..

Spare Parts

Item Number	Shim	Clamp screw	Wrench (for Clamp)	Clamp Pin	Spring
PDJNR2020K43	LSD42	LCS4	LW-3	LCL4	LSP4
PDJNR2525M43	LSD42	LCS4	LW-3	LCL4	LSP4
PDJNL2020K43	LSD42	LCS4	LW-3	LCL4	LSP4

WDHN/HDHN Multi Clamp Toolholders

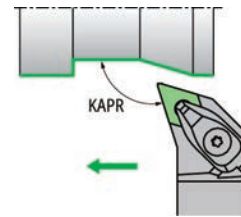
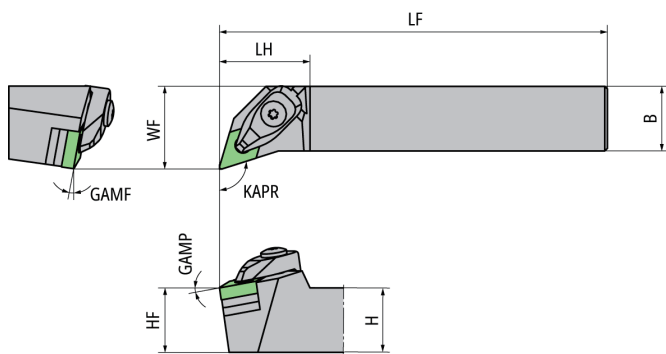

● Diagram shows right-hand tool

EDP	Item Number	Stock	Hand	B mm	GAMF °	GMAP °	H mm	HF mm	KAPR °	LF mm	LH mm	WF mm	Insert Gage
5682778	WDHNR2525M15	●	R	25	8	8	25	25	107.5	150	35	32	DN..1504.. (DN..1507..)
5682786	WDHNL2525M15	●	L	25	8	8	25	25	107.5	150	35	32	DN..1504.. (DN..1507..)
5701313	HDHNR2525M15	●	R	25	8	8	25	25	107.5	150	35	32	DNGX1507.. -
5701321	HDHNL2525M15	●	L	25	8	8	25	25	107.5	150	35	32	DNGX1507.. -

Spare Parts

Item Number	Clamp	Shim	Clamp screw	Screw (for Shim)	Wrench (for Clamp screw)	Wrench (for Shim)	Spring
WDHNR2525M15	DC6DN	ADN423	AOS-6*30W	FSS15-3.0*12	LLR-T20	LLR-T10	ASGL6-D
WDHNL2525M15	DC6DN	ADN423	AOS-6*30W	FSS15-3.0*12	LLR-T20	LLR-T10	ASGL6-D
HDHNR2525M15	HC6DN	ADN423	AOS-6*30W	FSS15-3.0*12	LLR-T20	LLR-T10	ASGL6-D
HDHNL2525M15	HC6DN	ADN423	AOS-6*30W	FSS15-3.0*12	LLR-T20	LLR-T10	ASGL6-D

WDNN/HDNN Multi Clamp Toolholders

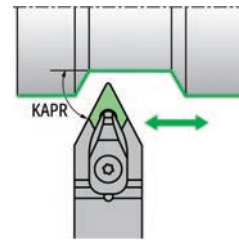
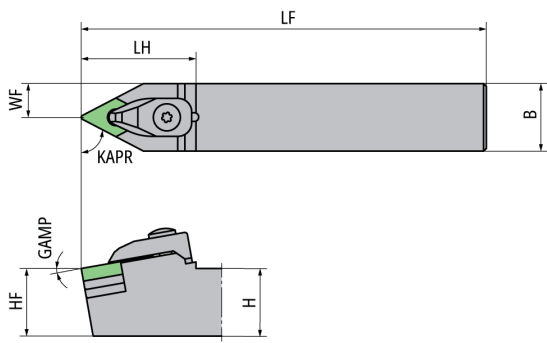

EDP	Item Number	Stock	Hand	B mm	GMAP °	H mm	HF mm	KAPR °	LF mm	LH mm	WF mm	Insert Gage	
5682760	WDNNN2525M15	●	N	25	10	25	25	62.5	150	42.5	12.5	DN..1504..	(DN..1507..)
5701305	HDNNN2525M15	●	N	25	10	25	25	62.5	150	42.5	12.5	DNGX1507..	-

Spare Parts

Item Number	Clamp	Shim	Clamp screw	Screw (for Shim)	Wrench (for Clamp screw)	Wrench (for Shim)	Spring
WDNNN2525M15	DC6DN	ADN423	AOS-6*30W	FSS15-3.0*12	LLR-T20	LLR-T10	ASGL6-D
HDNNN2525M15	HC6DN	ADN423	AOS-6*30W	FSS15-3.0*12	LLR-T20	LLR-T10	ASGL6-D

DN.. series/Inserts CBN

DNGA

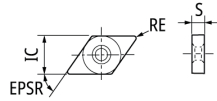

Steel	
Stainless Steel	
Cast Iron	● ● ● ● ○ ○
Non-Ferrous Material	
Heat Resistant Alloy	
Hardened Material	● ● ● ● ●
Others (non-metallic)	

Shape	Item Number (ISO)	CECC	EPSR °	IC mm	S mm	AN °	RE mm	D2 mm	Length of edge	No. of edge	S1 mm	CBN									
												B16 PVD	B22	B23	B30	B36	B6K PVD	B40	B52	B5K PVD	
	DNGA150402PQS01015	S01015	55	12.7	4.76	-	0.2	-	2.4	4	-								●	●	
	DNGA150402PQS01325	S01325	55	12.7	4.76	-	0.2	-	2.4	4	-								●	●	
	DNGA150402PQS01535	S01535	55	12.7	4.76	-	0.2	-	2.4	4	-								●	●	
	DNGA150402PQT01020	T01020	55	12.7	4.76	-	0.2	-	2.4	4	-										
	DNGA150404PDFNX	Up-sharp edge	55	12.7	4.76	-	0.4	-	2.2	2	-								●		
	DNGA150404PQFNX	Up-sharp edge	55	12.7	4.76	-	0.4	-	2.2	4	-									●	
	DNGA150404PQS01015	S01015	55	12.7	4.76	-	0.4	-	2.2	4	-								●	●	
	DNGA150404PQS01020	S01020	55	12.7	4.76	-	0.4	-	2.2	4	-								●	●	
	DNGA150404PQS01325	S01325	55	12.7	4.76	-	0.4	-	2.2	4	-								●	●	
	DNGA150404PQS01535	S01535	55	12.7	4.76	-	0.4	-	2.2	4	-								●	●	
	DNGA150404PQT01020	T01020	55	12.7	4.76	-	0.4	-	2.2	4	-										
	DNGA150408PDFNX	Up-sharp edge	55	12.7	4.76	-	0.8	-	1.9	2	-								●		
	DNGA150408PQFNX	Up-sharp edge	55	12.7	4.76	-	0.8	-	1.9	4	-									●	
	DNGA150408PQS01015	S01015	55	12.7	4.76	-	0.8	-	1.9	4	-								●	●	
	DNGA150408PQS01020	S01020	55	12.7	4.76	-	0.8	-	1.9	4	-								●	●	
	DNGA150408PQS01325	S01325	55	12.7	4.76	-	0.8	-	1.9	4	-								●	●	
	DNGA150408PQS01535	S01535	55	12.7	4.76	-	0.8	-	1.9	4	-								●	●	
	DNGA150408PQT01020	T01020	55	12.7	4.76	-	0.8	-	1.9	4	-										
	DNGA150412PDFNX	Up-sharp edge	55	12.7	4.76	-	1.2	-	2.6	2	-								●		
	DNGA150412PQFNX	Up-sharp edge	55	12.7	4.76	-	1.2	-	2.6	4	-									●	
	DNGA150412PQS01015	S01015	55	12.7	4.76	-	1.2	-	2.6	4	-								●	●	
	DNGA150412PQS01020	S01020	55	12.7	4.76	-	1.2	-	2.6	4	-								●	●	
	DNGA150412PQS01325	S01325	55	12.7	4.76	-	1.2	-	2.6	4	-								●	●	
	DNGA150412PQS01535	S01535	55	12.7	4.76	-	1.2	-	2.6	4	-								●	●	
	DNGA150412PQT01020	T01020	55	12.7	4.76	-	1.2	-	2.6	4	-										
	DNGA150416PQS01015	S01015	55	12.7	4.76	-	1.6	-	2.2	4	-								●	●	
	DNGA150416PQS01020	S01020	55	12.7	4.76	-	1.6	-	2.2	4	-								●	●	
	DNGA150416PQS01325	S01325	55	12.7	4.76	-	1.6	-	2.2	4	-								●	●	
	DNGA150416PQS01535	S01535	55	12.7	4.76	-	1.6	-	2.2	4	-								●	●	
	DNGA150416PQT01020	T01020	55	12.7	4.76	-	1.6	-	2.2	4	-										
	DNGA150420PQS01015	S01015	55	12.7	4.76	-	2	-	2.4	4	-								●		
	DNGA150420PQS01325	S01325	55	12.7	4.76	-	2	-	2.4	4	-								●	●	
	DNGA150420PQS01535	S01535	55	12.7	4.76	-	2	-	2.4	4	-									●	

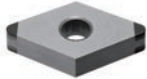

General Turning
Toolholders

DN.. series/Inserts PCD / Diamond Coating

DNMX

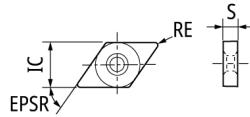

Steel									
Stainless Steel									
Cast Iron									
Non-Ferrous Material	●	●	●						
Heat Resistant Alloy									
Hardened Material									
Others (non-metallic)									●

Shape	Item Number (ISO)	CECC	EPSR °	IC mm	S mm	AN °	RE mm	No. of edge	PCD		Diamond Coating
									PD1	PD2	UC1
	DNMX150404PF	Up-sharp edge	55	12.7	4.76	-	0.4	1		●	
	DNMX150408PF	Up-sharp edge	55	12.7	4.76	-	0.8	1		●	

DN.. series/Inserts Carbide

DN..

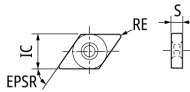

Steel	○	●	●	●	●	●	●	●	●
Stainless Steel	●	○	○	○	●	○	●	●	●
Cast Iron									●
Non-Ferrous Material							○	○	●
Heat Resistant Alloy		●	○	○					
Hardened Material		○	○	○					
Others (non-metallic)									●

Shape	Item Number (ISO)	CECC	EPSR °	IC mm	S mm	AN °	RE mm	BS mm	Carbide											
									PVD ST4	PVD DM4	PVD DT4	PVD QM3	PVD TM4	PVD VM1	PVD ZM3	CVD CP1	CVD CP7	Uncoated KM1		
	DNGG150404FNZP	Up-sharp edge	55	12.7	4.76	-	0.4	-		●	●									
	DNGG150408FNZP	Up-sharp edge	55	12.7	4.76	-	0.8	-		●	●									
	DNMG150408T00525Z5	T00525	55	12.7	4.76	-	0.8	-		●	●									
	DNMG150404TNG	T01025	55	12.7	4.76	-	0.4	-			●									
	DNMG150404G	-	55	12.7	4.76	-	0.4	-												●
	DNMG150408G	-	55	12.7	4.76	-	0.8	-												●
	DNMG150412G	-	55	12.7	4.76	-	1.2	-												●

General Turning
Toolholders
U1

SN..series/Toolholders

WSSN/TSSN/HSSN Multi Clamp Toolholders

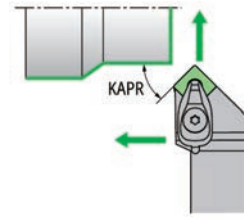
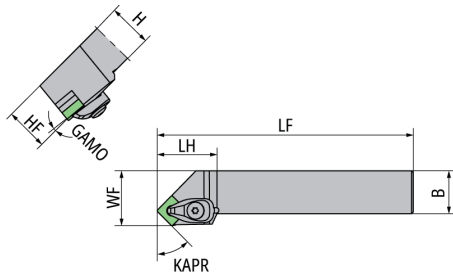

● Diagram shows right-hand tool

EDP	Item Number	Stock	Hand	B mm	GAMO °	H mm	HF mm	KAPR °	LF mm	LH mm	WF mm	Insert Gage
5682901	WSSNR2525M12	●	R	25	8	25	25	45	150	35	32	SN..1204.. (SN..1207..)
5682919	WSSNL2525M12	●	L	25	8	25	25	45	150	35	32	SN..1204.. (SN..1207..)
5701768	TSSNR2525M12	●	R	25	8	25	25	45	150	35	32	SN..1204.. (SN..1207..)
5701776	TSSNL2525M12	●	L	25	8	25	25	45	150	35	32	SN..1204.. (SN..1207..)
5701487	HSSNR2525M12	●	R	25	8	25	25	45	150	35	32	SNGX1207.. -
5701495	HSSNL2525M12	●	L	25	8	25	25	45	150	35	32	SNGX1207.. -

Spare Parts

Item Number	Clamp	Shim	Clamp screw	Screw (for Shim)	Wrench (for Clamp screw)	Wrench (for Shim)	Spring
WSSNR2525M12	DC6CN	ASN423	AOS-6*30W	FSS15-3.0*12	LLR-T20	LLR-T10	ASGL6-D
WSSNL2525M12	DC6CN	ASN423	AOS-6*30W	FSS15-3.0*12	LLR-T20	LLR-T10	ASGL6-D
TSSNR2525M12	TC6CN	ASN423	AOS-6*30W	FSS15-3.0*12	LLR-T20	LLR-T10	ASGL6-D
TSSNL2525M12	TC6CN	ASN423	AOS-6*30W	FSS15-3.0*12	LLR-T20	LLR-T10	ASGL6-D
HSSNR2525M12	HC6SN	ASN423	AOS-6*30W	FSS15-3.0*12	LLR-T20	LLR-T10	ASGL6-D
HSSNL2525M12	HC6SN	ASN423	AOS-6*30W	FSS15-3.0*12	LLR-T20	LLR-T10	ASGL6-D

General Turning
Toolholders

WSDN/TSDN/HSDN Multi Clamp Toolholders

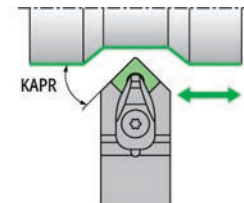
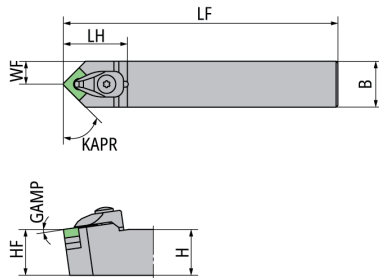

EDP	Item Number	Stock	Hand	B mm	GMAP °	H mm	HF mm	KAPR °	LF mm	LH mm	WF mm	Insert Gage
5682935	WSDNN2525M12	●	N	25	8	25	25	45	150	35	12.5	SN..1204.. (SN..1207..)
5682943	WSDNN3225P12	●	N	25	8	32	32	45	170	35	12.5	SN..1204.. (SN..1207..)
5701784	TSDNN2525M12	●	N	25	8	25	25	45	150	35	12.5	SN..1204.. (SN..1207..)
5701792	TSDNN3225P12	●	N	25	8	32	32	45	170	35	12.5	SN..1204.. (SN..1207..)
5701503	HSDNN2525M12	●	N	25	8	25	25	45	150	35	12.5	SNGX1207.. -
5701511	HSDNN3225P12	●	N	25	8	32	32	45	170	35	12.5	SNGX1207.. -

Spare Parts

Item Number	Clamp	Shim	Clamp screw	Screw (for Shim)	Wrench (for Clamp screw)	Wrench (for Shim)	Spring
WSDNN2525M12	DC6SN	ASN423	AOS-6*30W	FSS15-3.0*12	LLR-T20	LLR-T10	ASGL6-D
WSDNN3225P12	DC6SN	ASN423	AOS-6*30W	FSS15-3.0*12	LLR-T20	LLR-T10	ASGL6-D
TSDNN2525M12	TC6SN	ASN423	AOS-6*30W	FSS15-3.0*12	LLR-T20	LLR-T10	ASGL6-D
TSDNN3225P12	TC6SN	ASN423	AOS-6*30W	FSS15-3.0*12	LLR-T20	LLR-T10	ASGL6-D
HSDNN2525M12	HC6SN	ASN423	AOS-6*30W	FSS15-3.0*12	LLR-T20	LLR-T10	ASGL6-D
HSDNN3225P12	HC6SN	ASN423	AOS-6*30W	FSS15-3.0*12	LLR-T20	LLR-T10	ASGL6-D

CSSN

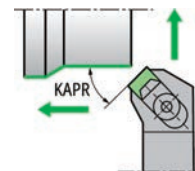
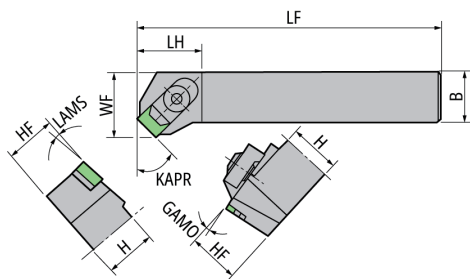

● Diagram shows right-hand tool

EDP	Item Number	Stock	Hand	B mm	GAMO °	H mm	HF mm	KAPR °	LAMS °	LF mm	LH mm	WF mm	Insert Gage
5700448	CSSNL2525M12	●	L	25	8	25	25	45	8	150	31	32	SN..1204.. (SN..1207..)
5857172	CSSNL3225P12	●	L	25	8	32	32	45	8	170	31	32	SN..1204.. (SN..1207..)

Spare Parts

Item Number	Clamp	Shim	Clamp screw	Screw (for Shim)	Wrench (for Clamp screw)	Snap
CSSNL2525M12	CC08M	ASN423	BS0835W	M3*12	LW-4	SR08
CSSNL3225P12	CC08M	ASN423	BS0835W	M3*12	LW-4	SR08

CSDNN

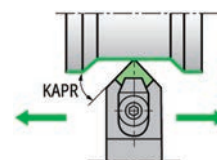
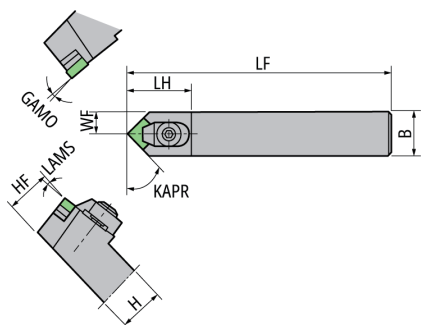

EDP	Item Number	Stock	Hand	B mm	GAMO °	H mm	HF mm	KAPR °	LAMS °	LF mm	LH mm	WF mm	Insert Gage
5700349	CSDNN2525M12	●	N	25	6	25	25	45	6	150	35	12.5	SN..1204.. (SN..1207..)

Spare Parts

Item Number	Clamp	Shim	Clamp screw	Screw (for Shim)	Wrench (for Clamp screw)	Snap
CSDNN2525M12	CC08M	ASN423	BS0835W	M3*12	LW-4	SR08

PSDN

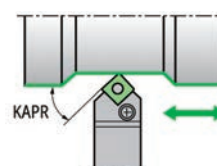
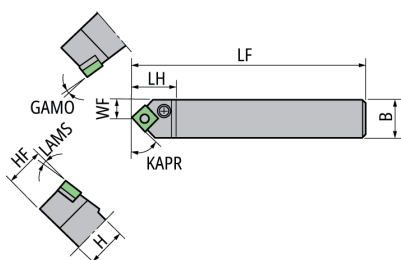

EDP	Item Number	Stock	Hand	B mm	GAMO °	H mm	HF mm	KAPR °	LAMS °	LF mm	LH mm	WF mm	Insert Gage
5523451	PSDNN2020K43	●	N	20	6	20	20	45	6	125	30	10	SN..1204..
5764006	PSDNN2525M43	●	N	25	6	25	25	45	6	150	30	12.5	SN..1204..

Spare Parts

Item Number	Shim	Clamp screw	Wrench (for Clamp screw)	Clamp Pin	Spring
PSDNN2020K43	LSS42	LCS4	LW-3	LCL4	LSP4
PSDNN2525M43	LSS42	LCS4	LW-3	LCL4	LSP4

C12

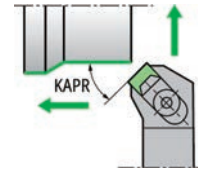
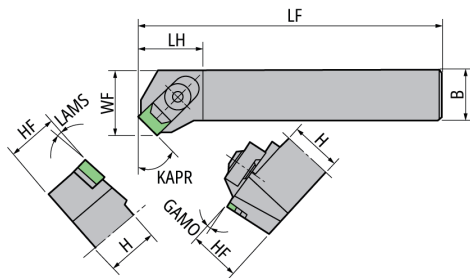

● Diagram shows right-hand tool

EDP	Item Number	Stock	Hand	B mm	GAMO °	H mm	HF mm	KAPR °	LAMS °	LF mm	LH mm	WF mm	Insert Gage
5538178	C12R-33	●	R	19	8	19	19	45	8	140	28	27	SN..1204.. -
5538194	C12R-44	●	R	25	8	25	25	45	8	160	31	35	SN..1204.. (SN..1207..)
5620869	C12R-45	●	R	25	8	32	32	45	8	160	31	35	SN..1204.. (SN..1207..)
5538186	C12L-33	●	L	19	8	19	19	45	8	140	28	27	SN..1204.. -
5538202	C12L-44	●	L	25	8	25	25	45	8	160	31	35	SN..1204.. (SN..1207..)
5637277	C12L-45	●	L	25	8	32	32	45	8	160	31	35	SN..1204.. (SN..1207..)

Spare Parts

Item Number	Clamp	Shim	Clamp screw	Screw (for Shim)	Wrench (for Clamp screw)	Snap
C12R-33	CC08MS	ASN423	BS0829W	M3*12	LW-4	SR08
C12R-44	CC08M	ASN423	BS0835W	M3*12	LW-4	SR08
C12R-45	CC08M	ASN423	BS0835W	M3*12	LW-4	SR08
C12L-33	CC08MS	ASN423	BS0829W	M3*12	LW-4	SR08
C12L-44	CC08M	ASN423	BS0835W	M3*12	LW-4	SR08
C12L-45	CC08M	ASN423	BS0835W	M3*12	LW-4	SR08

C14

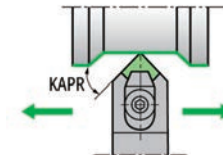
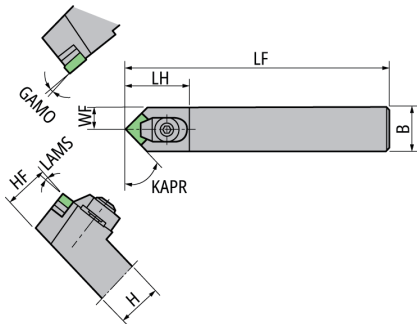

EDP	Item Number	Stock	Hand	B mm	GAMO °	H mm	HF mm	KAPR °	LAMS °	LF mm	LH mm	WF mm	Insert Gage
5538327	C14M-33	●	N	19	6	19	19	45	6	140	35	9.5	SN..1204.. -
5538335	C14M-34	●	N	19	6	25	25	45	6	160	35	9.5	SN..1204.. (SN..1207..)
5538343	C14M-44	●	N	25	6	25	25	45	6	160	35	12.5	SN..1204.. (SN..1207..)
5638036	C14M-45	●	N	25	6	32	32	45	6	160	35	12.5	SN..1204.. (SN..1207..)

Spare Parts

Item Number	Clamp	Shim	Clamp screw	Screw (for Shim)	Wrench (for Clamp screw)	Snap
C14M-33	CC08M	ASN423	BS0829W	M3*12	LW-4	SR08
C14M-34	CC08M	ASN423	BS0835W	M3*12	LW-4	SR08
C14M-44	CC08M	ASN423	BS0835W	M3*12	LW-4	SR08
C14M-45	CC08M	ASN423	BS0835W	M3*12	LW-4	SR08

C13

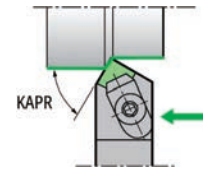
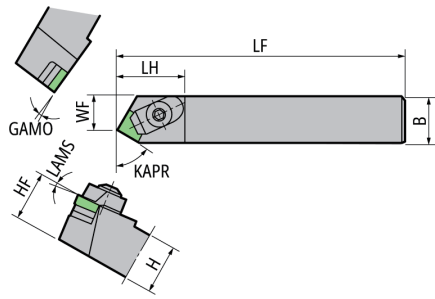

● Diagram shows right-hand tool

EDP	Item Number	Stock	Hand	B mm	GAMO °	H mm	HF mm	KAPR °	LAMS °	LF mm	LH mm	WF mm	Insert Gage
5538244	C13R-33	●	R	19	6	19	19	60	6	140	35	12.5	SN..1204.. (SN..1207..)
5538269	C13R-34	●	R	19	6	25	25	60	6	160	35	12.5	SN..1204.. (SN..1207..)
5538277	C13R-44	●	R	25	6	25	25	60	6	160	35	18.5	SN..1204.. (SN..1207..)
5684816	C13R-45	●	R	25	6	33	32	60	6	160	35	18.5	SN..1204.. (SN..1207..)
5538251	C13L-33	●	L	19	6	19	19	60	6	140	35	12.5	SN..1204.. -
5538285	C13L-44	●	L	25	6	25	25	60	6	160	35	18.5	SN..1204.. (SN..1207..)
5802863	C13L-45	●	L	25	6	32	32	60	6	160	35	18.5	SN..1204.. (SN..1207..)

Spare Parts

Item Number	Clamp	Shim	Clamp screw	Screw (for Shim)	Wrench (for Clamp screw)	Snap
C13R-33	CC08M	ASN423	BS0829W	M3*12	LW-4	SR08
C13R-34	CC08M	ASN423	BS0835W	M3*12	LW-4	SR08
C13R-44	CC08M	ASN423	BS0835W	M3*12	LW-4	SR08
C13R-45	CC08M	ASN423	BS0835W	M3*12	LW-4	SR08
C13L-33	CC08M	ASN423	BS0829W	M3*12	LW-4	SR08
C13L-44	CC08M	ASN423	BS0835W	M3*12	LW-4	SR08
C13L-45	CC08M	ASN423	BS0835W	M3*12	LW-4	SR08

PSBN

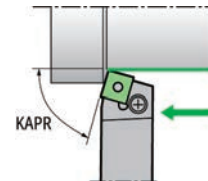
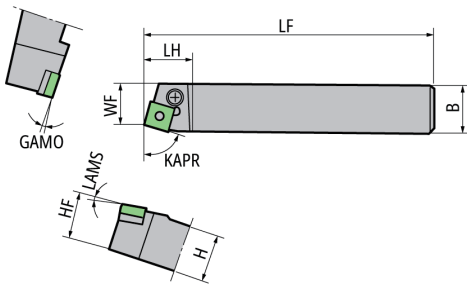

● Diagram shows right-hand tool

EDP	Item Number	Stock	Hand	B mm	GAMO °	H mm	HF mm	KAPR °	LAMS °	LF mm	LH mm	WF mm	Insert Gage
5934492	PSBNL2020K43	●	L	20	6	20	20	75	6	125	28	17	SN..1204..
5934518	PSBNR2020K43	●	R	20	6	20	20	75	6	125	28	17	SN..1204..

Spare Parts

Item Number	Shim	Clamp screw	Wrench (for Clamp screw)	Clamp Pin	Spring
PSBNL2020K43	LSS42	LCS4	LW-3	LCL4	LSP4
PSBNR2020K43	LSS42	LCS4	LW-3	LCL4	LSP4

C11

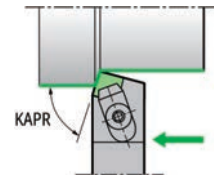
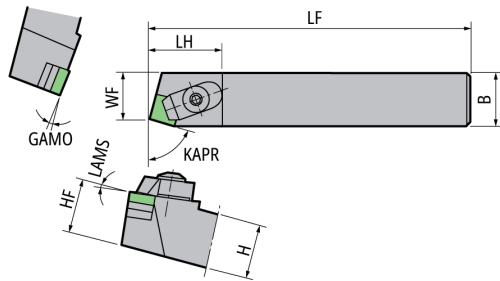

● Diagram shows right-hand tool

EDP	Item Number	Stock	Hand	B mm	GAMO °	H mm	HF mm	KAPR °	LAMS °	LF mm	LH mm	WF mm	Insert Gage	
5538608	C11R-33	●	R	19	6	19	19	75	6	140	34	15.5	SN..1204..	(SN..1207..)
5538624	C11R-34	●	R	19	6	25	25	75	6	160	34	15.5	SN..1204..	(SN..1207..)
5538632	C11R-44	●	R	25	6	25	25	75	6	160	34	21.5	SN..1204..	(SN..1207..)
5778170	C11R-45	●	R	25	6	32	32	75	6	160	34	21.5	SN..1204..	(SN..1207..)
5538616	C11L-33	●	L	19	6	19	19	75	6	140	34	15.5	SN..1204..	-
5538640	C11L-44	●	L	25	6	25	25	75	6	160	34	21.5	SN..1204..	(SN..1207..)
5710876	C11L-45	●	L	25	6	32	32	75	6	160	34	21.5	SN..1204..	(SN..1207..)

Spare Parts

Item Number	Clamp	Shim	Clamp screw	Screw (for Shim)	Wrench (for Shim)	Snap
C11R-33	CC08M	ASN423	BS0829W	M3*12	LW-4	SR08
C11R-34	CC08M	ASN423	BS0835W	M3*12	LW-4	SR08
C11R-44	CC08M	ASN423	BS0835W	M3*12	LW-4	SR08
C11R-45	CC08M	ASN423	BS0835W	M3*12	LW-4	SR08
C11L-33	CC08M	ASN423	BS0829W	M3*12	LW-4	SR08
C11L-44	CC08M	ASN423	BS0835W	M3*12	LW-4	SR08
C11L-45	CC08M	ASN423	BS0835W	M3*12	LW-4	SR08

C15

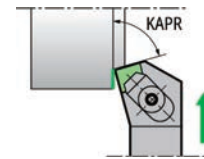
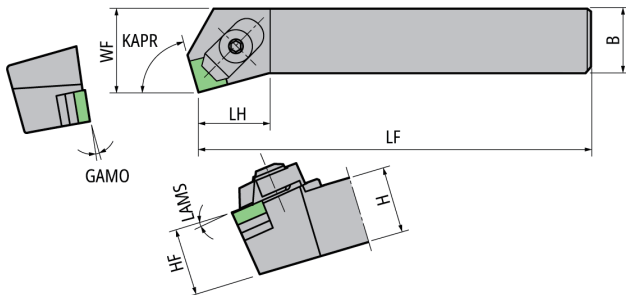

● Diagram shows right-hand tool

EDP	Item Number	Stock	Hand	B mm	GAMO °	H mm	HF mm	KAPR °	LAMS °	LF mm	LH mm	WF mm	Insert Gage	
5566070	C15R-33	●	R	19	6	19	19	75	6	140	29	25	SN..1204..	-
5538236	C15R-44	●	R	25	6	25	25	75	6	160	28	31	SN..1204..	(SN..1207..)
5802848	C15R-45	●	R	25	6	32	32	75	6	160	28	31	SN..1204..	(SN..1207..)
5538210	C15L-33	●	L	19	6	19	19	75	6	140	29	25	SN..1204..	-
5538228	C15L-34	●	L	19	6	25	25	75	6	160	29	25	SN..1204..	(SN..1207..)
5576863	C15L-44	●	L	25	6	25	25	75	6	160	28	31	SN..1204..	(SN..1207..)
5759865	C15L-45	●	L	25	6	32	32	75	6	160	28	31	SN..1204..	(SN..1207..)
5538368	C16L-33	●	L	19	6	19	19	75	6	140	32	22	SN..1204..	-
5538384	C16L-44	●	L	25	6	25	25	75	6	160	25	25	SN..1204..	(SN..1207..)
5746862	C16L-45	●	L	25	6	32	32	75	6	160	25	25	SN..1204..	(SN..1207..)

Spare Parts

Item Number	Clamp	Shim	Clamp screw	Screw (for Shim)	Wrench (for Clamp screw)	Snap
C15R-33	CC08M	ASN423	BS0829W	M3*12	LW-4	SR08
C15R-44	CC08M	ASN423	BS0835W	M3*12	LW-4	SR08
C15R-45	CC08M	ASN423	BS0835W	M3*12	LW-4	SR08
C15L-33	CC08M	ASN423	BS0829W	M3*12	LW-4	SR08
C15L-34	CC08M	ASN423	BS0835W	M3*12	LW-4	SR08
C15L-44	CC08M	ASN423	BS0835W	M3*12	LW-4	SR08
C15L-45	CC08M	ASN423	BS0835W	M3*12	LW-4	SR08
C16L-33	CC08MS	ASN423	BS0829W	M3*12	LW-4	SR08
C16L-44	CC08MS	ASN423	BS0835W	M3*12	LW-4	SR08
C16L-45	CC08MS	ASN423	BS0835W	M3*12	LW-4	SR08

C16

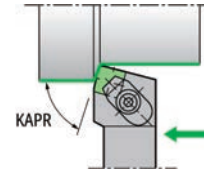
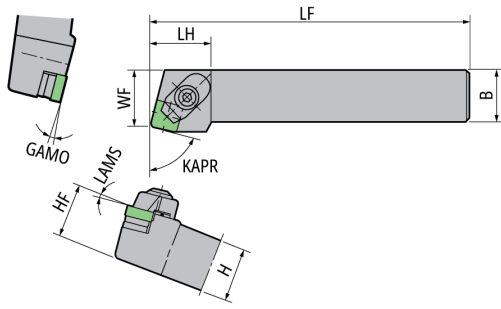

● Diagram shows right-hand tool

EDP	Item Number	Stock	Hand	B mm	GAMO °	H mm	HF mm	KAPR °	LAMS °	LF mm	LH mm	WF mm	Insert Gage	
5538350	C16R-33	●	R	19	6	19	19	75	6	140	32	22	SN..1204..	-
5538376	C16R-44	●	R	25	6	25	25	75	6	160	25	25	SN..1204..	(SN..1207..)
5684824	C16R-45	●	R	25	6	32	32	75	6	160	25	25	SN..1204..	(SN..1207..)

Spare Parts

Item Number	Clamp	Shim	Clamp screw	Screw (for Shim)	Wrench (for Clamp screw)	Snap
C16R-33	CC08MS	ASN423	BS0829W	M3*12	LW-4	SR08
C16R-44	CC08MS	ASN423	BS0835W	M3*12	LW-4	SR08
C16R-45	CC08MS	ASN423	BS0835W	M3*12	LW-4	SR08

C17

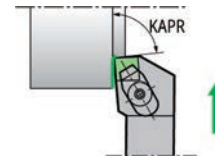
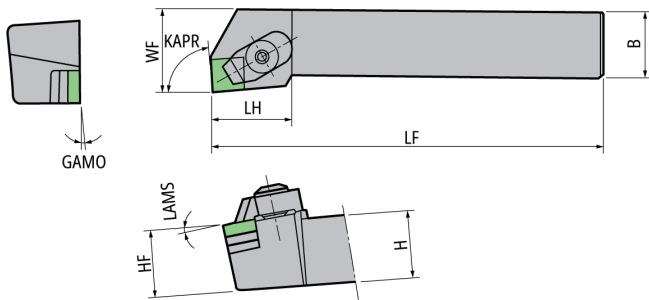

● Diagram shows right-hand tool

EDP	Item Number	Stock	Hand	B mm	GAMO °	H mm	HF mm	KAPR °	LAMS °	LF mm	LH mm	WF mm	Insert Gage	
5538145	C17R-33	●	R	19	6	19	19	85	6	140	30	24	SN..1204..	-
5538152	C17R-44	●	R	25	6	25	25	85	6	160	30	30	SN..1204..	(SN..1207..)
5755400	C17R-45	●	R	25	6	32	32	85	6	160	30	30	SN..1204..	(SN..1207..)
5538160	C17L-44	●	L	25	6	25	25	85	6	160	30	30	SN..1204..	(SN..1207..)
5743281	C17L-45	●	L	25	6	32	32	85	6	160	30	30	SN..1204..	(SN..1207..)

Spare Parts

Item Number	Clamp	Shim	Clamp screw	Screw (for Shim)	Wrench (for Clamp screw)	Snap
C17R-33	CC08M	ASN423	BS0829W	M3*12	LW-4	SR08
C17R-44	CC08M	ASN423	BS0835W	M3*12	LW-4	SR08
C17R-45	CC08M	ASN423	BS0835W	M3*12	LW-4	SR08
C17L-44	CC08M	ASN423	BS0835W	M3*12	LW-4	SR08
C17L-45	CC08M	ASN423	BS0835W	M3*12	LW-4	SR08

CSHN

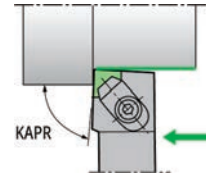
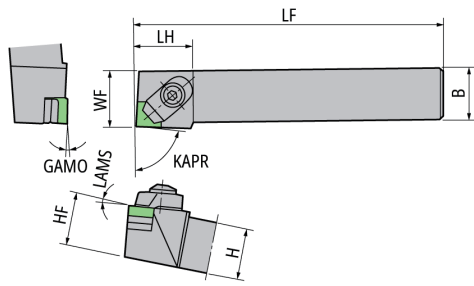

● Diagram shows right-hand tool

EDP	Item Number	Stock	Hand	B mm	GAMO °	H mm	HF mm	KAPR °	LAMS °	LF mm	LH mm	WF mm	Insert Gage	
5692488	CSHNR2525M12	●	R	25	6	25	25	85	6	150	30	27	SN..1204..	(SN..1207..)
5692470	CSHNL2525M12	●	L	25	6	25	25	85	6	150	30	27	SN..1204..	(SN..1207..)

Spare Parts

Item Number	Clamp	Shim	Clamp screw	Screw (for Shim)	Wrench (for Clamp screw)	Snap
CSHNR2525M12	CC08M	ASN423	BS0835W	M3*12	LW-4	SR08
CSHNL2525M12	CC08M	ASN423	BS0835W	M3*12	LW-4	SR08

SN.. series/Inserts CBN

SNGA

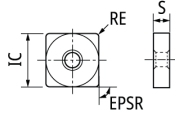

Steel	
Stainless Steel	
Cast Iron	● ● ● ● ○ ○
Non-Ferrous Material	
Heat Resistant Alloy	
Hardened Material	● ● ● ● ●
Others (non-metallic)	

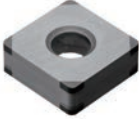
Shape	Item Number (ISO)	CECC	EPSR °	IC mm	S mm	AN °	RE mm	D2 mm	Length of edge	No. of edge	S1 mm	CBN									
												B16 PVD	B22	B23	B30	B36	B6K PVD	B40	B52	B5K PVD	
	SNGA120402PES01325	S01325	90	12.7	4.76	-	0.2	-	2.3	8	-						●	●	●		
	SNGA120404PES01015	S01015	90	12.7	4.76	-	0.4	-	2.3	8	-						●	●			
	SNGA120404PES01020	S01020	90	12.7	4.76	-	0.4	-	2.3	8	-		●								
	SNGA120404PES01325	S01325	90	12.7	4.76	-	0.4	-	2.3	8	-					●					
	SNGA120404PES01535	S01535	90	12.7	4.76	-	0.4	-	2.3	8	-						●	●			
	SNGA120404PET01020	T01020	90	12.7	4.76	-	0.4	-	2.3	8	-			●				●	●		
	SNGA120408PES01015	S01015	90	12.7	4.76	-	0.8	-	2.3	8	-							●	●		
	SNGA120408PES01020	S01020	90	12.7	4.76	-	0.8	-	2.3	8	-			●							
	SNGA120408PES01325	S01325	90	12.7	4.76	-	0.8	-	2.3	8	-					●					
	SNGA120408PES01535	S01535	90	12.7	4.76	-	0.8	-	2.3	8	-							●	●		
	SNGA120408PET01020	T01020	90	12.7	4.76	-	0.8	-	2.3	8	-				●			●	●		
	SNGA120412PES01015	S01015	90	12.7	4.76	-	1.2	-	2.8	8	-					●		●	●		
	SNGA120412PES01020	S01020	90	12.7	4.76	-	1.2	-	2.8	8	-			●							
	SNGA120412PES01325	S01325	90	12.7	4.76	-	1.2	-	2.8	8	-					●					
	SNGA120412PES01535	S01535	90	12.7	4.76	-	1.2	-	2.8	8	-							●	●		
	SNGA120412PET01020	T01020	90	12.7	4.76	-	1.2	-	2.8	8	-					●					
	SNGA120416PES01015	S01015	90	12.7	4.76	-	1.6	-	2.8	8	-								●		
	SNGA120416PES01325	S01325	90	12.7	4.76	-	1.6	-	2.8	8	-					●					
SNGA120416PET01020	T01020	90	12.7	4.76	-	1.6	-	2.8	8	-					●						

SNMN

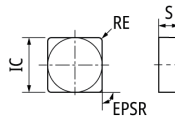

Steel	
Stainless Steel	
Cast Iron	● ● ● ● ○ ○
Non-Ferrous Material	
Heat Resistant Alloy	
Hardened Material	● ● ● ● ●
Others (non-metallic)	



Shape	Item Number (ISO)	CECC	EPSR °	IC mm	S mm	AN °	RE mm	D2 mm	Length of edge	No. of edge	S1 mm	CBN									
												B16 PVD	B22	B23	B30	B36	B6K PVD	B40	B52	B5K PVD	
	SNMN120408ST01025	T01025	90	12.7	4.76	-	0.8	-	-	8	-	●									
	SNMN120412ST02025	T02025	90	12.7	4.76	-	1.2	-	-	8	-	●									
	SNMN120416ST02025	T02025	90	12.7	4.76	-	1.6	-	-	8	-	●									

SN.. series/Inserts Carbide

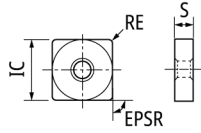
SNMG



Steel	○	●	●	●	●	●	●	●	●
Stainless Steel	●	○	○	○	●	○	●	●	●
Cast Iron									●
Non-Ferrous Material						○	○		●
Heat Resistant Alloy		●	○	○					
Hardened Material		○	○	○					
Others (non-metallic)									●

Shape	Item Number (ISO)	CECC	EPSR °	IC mm	S mm	AN °	RE mm	BS mm	Carbide												
									PVD	PVD	PVD	PVD	PVD	PVD	PVD	PVD	CVD	CVD	Uncoated		
									ST4	DM4	DT4	QM3	TM4	VM1	ZM3	CP1	CP7	KM1			
	SNMG120408T00525Z5	T00525	90	12.7	4.76	-	0.8	-		●		●									
	SNMG120408G	-	90	12.7	4.76	-	0.8	-													●
	SNMG120412G	-	90	12.7	4.76	-	1.2	-													●
	SNMG120416G	-	90	12.7	4.76	-	1.6	-													●

General Turning
Toolholders

VN..series/Toolholders

WVJN/HVJN Multi Clamp Toolholders

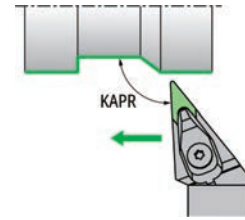
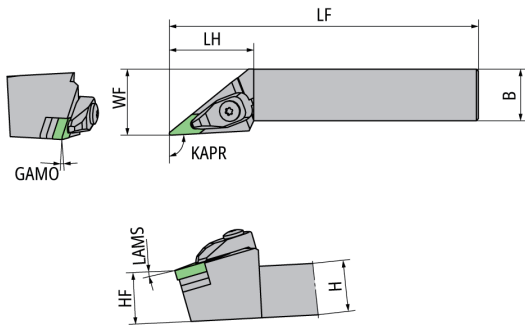

● Diagram shows right-hand tool

EDP	Item Number	Stock	Hand	B mm	GAMO °	H mm	HF mm	KAPR °	LAMS °	LF mm	LH mm	WF mm	Insert Gage
5682828	WVJNR2525M16	●	R	25	6	25	25	93	13	150	41	32	VN..1604.. (VN..1607..)
5682844	WVJNR3225P16	●	R	25	6	32	32	93	13	170	41	32	VN..1604.. (VN..1607..)
5682836	WVJNL2525M16	●	L	25	6	25	25	93	13	150	41	32	VN..1604.. (VN..1607..)
5682851	WVJNL3225P16	●	L	25	6	32	32	93	13	170	41	32	VN..1604.. (VN..1607..)
5701396	HVJNR2525M16	●	R	25	6	25	25	93	13	150	41	32	VNGX1607.. -
5701420	HVJNR3225P16	●	R	25	6	32	32	93	13	170	41	32	VNGX1607.. -
5701412	HVJNL2525M16	●	L	25	6	25	25	93	13	150	41	32	VNGX1607.. -
5701438	HVJNL3225P16	●	L	25	6	32	32	93	13	170	41	32	VNGX1607.. -

Spare Parts

Item Number	Clamp	Shim	Clamp screw	Screw (for Shim)	Wrench (for Clamp screw)	Wrench (for Shim)	Spring
WVJNR2525M16	DC6VN	AVN323	AOS-6*30W	FSS15-3.0*12	LLR-T20	LLR-T10	ASGL6-D
WVJNR3225P16	DC6VN	AVN323	AOS-6*30W	FSS15-3.0*12	LLR-T20	LLR-T10	ASGL6-D
WVJNL2525M16	DC6VN	AVN323	AOS-6*30W	FSS15-3.0*12	LLR-T20	LLR-T10	ASGL6-D
WVJNL3225P16	DC6VN	AVN323	AOS-6*30W	FSS15-3.0*12	LLR-T20	LLR-T10	ASGL6-D
HVJNR2525M16	HC6VN	AVN323	AOS-6*30W	FSS15-3.0*12	LLR-T20	LLR-T10	ASGL6-D
HVJNR3225P16	HC6VN	AVN323	AOS-6*30W	FSS15-3.0*12	LLR-T20	LLR-T10	ASGL6-D
HVJNL2525M16	HC6VN	AVN323	AOS-6*30W	FSS15-3.0*12	LLR-T20	LLR-T10	ASGL6-D
HVJNL3225P16	HC6VN	AVN323	AOS-6*30W	FSS15-3.0*12	LLR-T20	LLR-T10	ASGL6-D

WVPN/HVPN Multi Clamp Toolholders

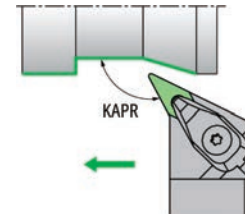
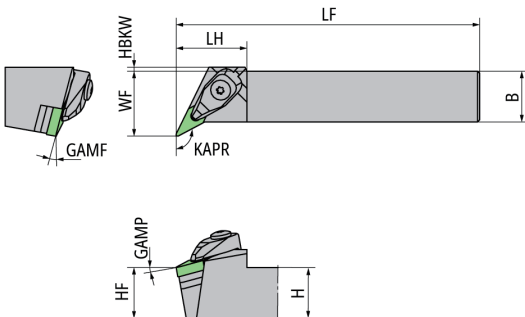

● Diagram shows right-hand tool

EDP	Item Number	Stock	Hand	B mm	GAMF °	GMAP °	H mm	HBKW mm	HF mm	KAPR °	LF mm	LH mm	WF mm	Insert Gage
5682885	WVPNR2525M16	●	R	25	10	10	25	2	25	117.5	150	35	32	VN..1604.. (VN..1607..)
5682893	WVPNL2525M16	●	L	25	10	10	25	2	25	117.5	150	35	32	VN..1604.. (VN..1607..)
5701461	HVPNR2525M16	●	R	25	10	10	25	2	25	117.5	150	35	32	VNGX1607.. -
5701479	HVPNL2525M16	●	L	25	10	10	25	2	25	117.5	150	35	32	VNGX1607.. -

Spare Parts

Item Number	Clamp	Shim	Clamp screw	Screw (for Shim)	Wrench (for Clamp screw)	Wrench (for Shim)	Spring
WVPNR2525M16	DC6VN	AVN323	AOS-6*30W	FSS15-3.0*12	LLR-T20	LLR-T10	ASGL6-D
WVPNL2525M16	DC6VN	AVN323	AOS-6*30W	FSS15-3.0*12	LLR-T20	LLR-T10	ASGL6-D
HVPNR2525M16	HC6VN	AVN323	AOS-6*30W	FSS15-3.0*12	LLR-T20	LLR-T10	ASGL6-D
HVPNL2525M16	HC6VN	AVN323	AOS-6*30W	FSS15-3.0*12	LLR-T20	LLR-T10	ASGL6-D

WVNN/HVNN Multi Clamp Toolholders

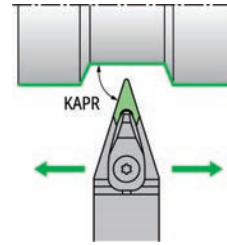
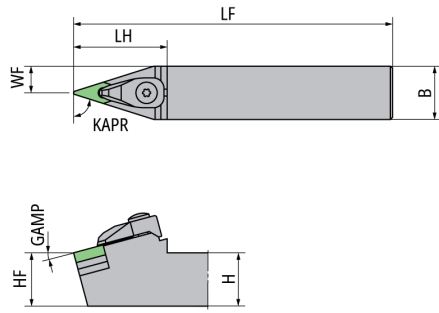

EDP	Item Number	Stock	Hand	B mm	GMAP °	H mm	HF mm	KAPR °	LF mm	LH mm	WF mm	Insert Gage
5682877	WVNN2525M16	●	N	25	15	25	25	72.5	150	44	12.5	VN..1604.. (VN..1607..)
5701453	HVNN2525M16	●	N	25	15	25	25	72.5	150	44	12.5	VNGX1607.. -

Spare Parts

Item Number	Clamp	Shim	Clamp screw	Screw (for Shim)	Wrench (for Clamp screw)	Wrench (for Shim)	Spring
WVNN2525M16	DC6VN	AVN323	AOS-6*30W	FSS15-3.0*12	LLR-T20	LLR-T10	ASGL6-D
HVNN2525M16	HC6VN	AVN323	AOS-6*30W	FSS15-3.0*12	LLR-T20	LLR-T10	ASGL6-D

VN.. series/Inserts CBN

VNGA

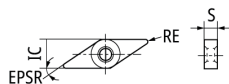

Steel																				
Stainless Steel																				
Cast Iron	●	●	●	●															○	○
Non-Ferrous Material																				
Heat Resistant Alloy																				
Hardened Material																				
Others (non-metallic)																				

Shape	Item Number (ISO)	CECC	EPSR °	IC mm	S mm	AN °	RE mm	D2 mm	Length of edge	No. of edge	S1 mm	CBN										
												B16 PVD	B22	B23	B30	B36	B6K PVD	B40	B52	B5K	PVD	
	VNGA160401PQS01015	S01015	35	9.525	4.76	-	0.1	-	2.7	4	-											●
	VNGA160401PQS01535	S01535	35	9.525	4.76	-	0.1	-	2.7	4	-											●
	VNGA160402PDFNX	Up-sharp edge	35	9.525	4.76	-	0.2	-	2.6	2	-											
	VNGA160402PQFNX	Up-sharp edge	35	9.525	4.76	-	0.2	-	2.6	4	-											
	VNGA160402PQS01015	S01015	35	9.525	4.76	-	0.2	-	2.6	4	-											●
	VNGA160402PQS01325	S01325	35	9.525	4.76	-	0.2	-	2.6	4	-											●
	VNGA160402PQS01535	S01535	35	9.525	4.76	-	0.2	-	2.6	4	-											●
	VNGA160402PQT01020	T01020	35	9.525	4.76	-	0.2	-	2.6	4	-											●
	VNGA160404PDFNX	Up-sharp edge	35	9.525	4.76	-	0.4	-	2.5	2	-											
	VNGA160404PQFNX	Up-sharp edge	35	9.525	4.76	-	0.4	-	2.5	4	-											●
	VNGA160404PQS01015	S01015	35	9.525	4.76	-	0.4	-	2.5	4	-											●
	VNGA160404PQS01325	S01325	35	9.525	4.76	-	0.4	-	2.5	4	-											●
	VNGA160404PQS01535	S01535	35	9.525	4.76	-	0.4	-	2.5	4	-											●
	VNGA160404PQT01020	T01020	35	9.525	4.76	-	0.4	-	2.5	4	-											●
	VNGA160408PDFNX	Up-sharp edge	35	9.525	4.76	-	0.8	-	1.6	2	-											
	VNGA160408PQFNX	Up-sharp edge	35	9.525	4.76	-	0.8	-	1.6	4	-											●
	VNGA160408PQS01015	S01015	35	9.525	4.76	-	0.8	-	1.6	4	-											●
	VNGA160408PQS01325	S01325	35	9.525	4.76	-	0.8	-	1.6	4	-											●
	VNGA160408PQS01535	S01535	35	9.525	4.76	-	0.8	-	1.6	4	-											●
	VNGA160408PQT01020	T01020	35	9.525	4.76	-	0.8	-	1.6	4	-											●
	VNGA160412PDFNX	Up-sharp edge	35	9.525	4.76	-	1.2	-	2.7	2	-											
	VNGA160412PQS01015	S01015	35	9.525	4.76	-	1.2	-	2.7	4	-											●
	VNGA160412PQS01325	S01325	35	9.525	4.76	-	1.2	-	2.7	4	-											●
	VNGA160412PQS01535	S01535	35	9.525	4.76	-	1.2	-	2.7	4	-											●
	VNGA160412PQT01020	T01020	35	9.525	4.76	-	1.2	-	2.7	4	-											●

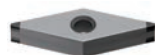

General Turning
Toolholders

VN.. series/Inserts Carbide

VN..

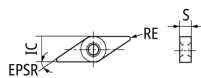

Steel	○	●	●	●	●	●	●	●	●	●	●	●	●	●	●	●	●	●	●	●	●
Stainless Steel	●	○	○	○	○	○	○	○	○	○	○	○	○	○	○	○	○	○	○	○	○
Cast Iron																					
Non-Ferrous Material																					
Heat Resistant Alloy	●	○	○	○	○	○	○	○	○	○	○	○	○	○	○	○	○	○	○	○	○
Hardened Material	○	○	○	○	○	○	○	○	○	○	○	○	○	○	○	○	○	○	○	○	○
Others (non-metallic)																					

Shape	Item Number (ISO)	CECC	EPSR °	IC mm	S mm	AN °	RE mm	BS mm	Carbide										Uncoated KM1			
									PVD ST4	PVD DM4	PVD DT4	PVD QM3	PVD TM4	PVD VM1	PVD ZM3	PVD CP1	PVD CP7	PVD CVD				
	VNGG160402FNZP	Up-sharp edge	35	9.525	4.76	-	0.2	-														
	VNGG160404FNZP	Up-sharp edge	35	9.525	4.76	-	0.4	-														
	VNGG160408FNZP	Up-sharp edge	35	9.525	4.76	-	0.8	-														
	VNMG160404G	-	35	9.525	4.76	-	0.4	-														
	VNMG160408G	-	35	9.525	4.76	-	0.8	-														
	VNMG160412G	-	35	9.525	4.76	-	1.2	-														
	VNMG160404T00525AM1	T00525	35	9.525	4.76	-	0.4	-														
	VNMG160408T00525AM1	T00525	35	9.525	4.76	-	0.8	-														

TN.. series/Toolholders

WTGN/TTGN Multi Clamp Toolholders

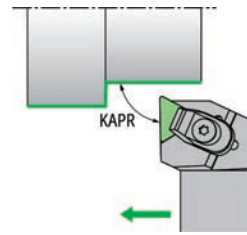
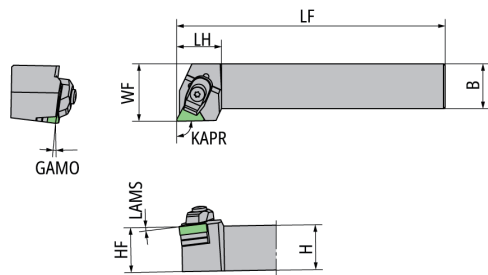

● Diagram shows right-hand tool

EDP	Item Number	Stock	Hand	B mm	GAMO °	H mm	HF mm	KAPR °	LAMS °	LF mm	LH mm	WF mm	Insert Gage
5682976	WTGNR2525M16	●	R	25	6	25	25	91	6	150	25	32	TN..1604.. (TN..1607..)
5682984	WTGNL2525M16	●	L	25	6	25	25	91	6	150	25	32	TN..1604.. (TN..1607..)
5701826	TTGNR2525M16	●	R	25	6	25	25	91	6	150	25	32	TN..1604.. (TN..1607..)
5701834	TTGNL2525M16	●	L	25	6	25	25	91	6	150	25	32	TN..1604.. (TN..1607..)

Spare Parts

Item Number	Clamp	Shim	Clamp screw	Screw (for Shim)	Wrench (for Clamp screw)	Wrench (for Shim)	Spring
WTGNR2525M16	DC5TN	ATN323	AOS-5*26W	FSS15-3.0*12	LLR-T15	LLR-T10	ASGL5-D
WTGNL2525M16	DC5TN	ATN323	AOS-5*26W	FSS15-3.0*12	LLR-T15	LLR-T10	ASGL5-D
TTGNR2525M16	TC5TN	ATN323	AOS-5*26W	FSS15-3.0*12	LLR-T15	LLR-T10	ASGL5-D
TTGNL2525M16	TC5TN	ATN323	AOS-5*26W	FSS15-3.0*12	LLR-T15	LLR-T10	ASGL5-D

WTFN/TTFN Multi Clamp Toolholders

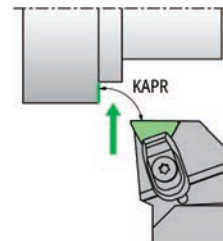
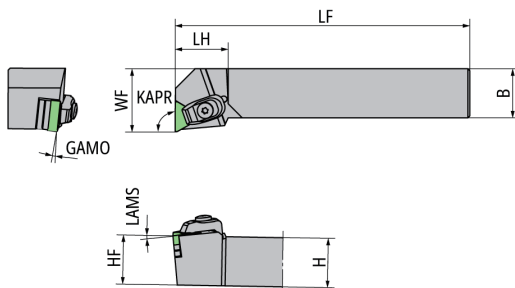

● Diagram shows right-hand tool

EDP	Item Number	Stock	Hand	B mm	GAMO °	H mm	HF mm	KAPR °	LAMS °	LF mm	LH mm	WF mm	Insert Gage
5682992	WTFNR2525M16	●	R	25	6	25	25	91	6	150	27	32	TN..1604.. (TN..1607..)
5683008	WTFNL2525M16	●	L	25	6	25	25	91	6	150	27	32	TN..1604.. (TN..1607..)
5701859	TTFNR2525M16	●	R	25	6	25	25	91	6	150	27	32	TN..1604.. (TN..1607..)
5701867	TTFNL2525M16	●	L	25	6	25	25	91	6	150	27	32	TN..1604.. (TN..1607..)

Spare Parts

Item Number	Clamp	Shim	Clamp screw	Screw (for Shim)	Wrench (for Clamp screw)	Wrench (for Shim)	Spring
WTFNR2525M16	DC5TN	ATN323	AOS-5*26W	FSS15-3.0*12	LLR-T15	LLR-T10	ASGL5-D
WTFNL2525M16	DC5TN	ATN323	AOS-5*26W	FSS15-3.0*12	LLR-T15	LLR-T10	ASGL5-D
TTFNR2525M16	TC5TN	ATN323	AOS-5*26W	FSS15-3.0*12	LLR-T15	LLR-T10	ASGL5-D
TTFNL2525M16	TC5TN	ATN323	AOS-5*26W	FSS15-3.0*12	LLR-T15	LLR-T10	ASGL5-D

C21

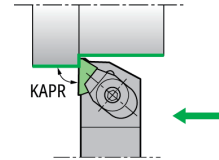
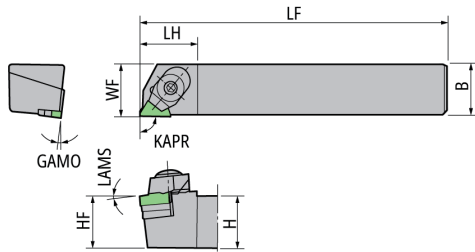

● Diagram shows right-hand tool

EDP	Item Number	Stock	Hand	B mm	GAMO °	H mm	HF mm	KAPR °	LAMS °	LF mm	LH mm	WF mm	Insert Gage	
5538426	C21R-33	●	R	19	6	19	19	91	6	140	28	19	TN..1604..	-
5538442	C21R-44	●	R	25	6	25	25	91	6	160	28	25	TN..1604..	(TN..1607..)
5760558	C21R-45	●	R	25	6	32	32	91	6	160	28	25	TN..1604..	(TN..1607..)
5538434	C21L-34	●	L	19	6	25	25	91	6	160	28	19	TN..1604..	(TN..1607..)
5538459	C21L-44	●	L	25	6	25	25	91	6	160	28	25	TN..1604..	(TN..1607..)
5650411	C21L-45	●	L	25	6	32	32	91	6	160	28	25	TN..1604..	(TN..1607..)

Spare Parts

Item Number	Clamp	Shim	Clamp screw	Screw (for Shim)	Wrench (for Clamp screw)	Snap
C21R-33	CC08MS	ATN323	BS0829W	M3*12	LW-4	SR08
C21R-44	CC08MS	ATN323	BS0835W	M3*12	LW-4	SR08
C21R-45	CC08MS	ATN323	BS0835W	M3*12	LW-4	SR08
C21L-34	CC08MS	ATN323	BS0835W	M3*12	LW-4	SR08
C21L-44	CC08MS	ATN323	BS0835W	M3*12	LW-4	SR08
C21L-45	CC08MS	ATN323	BS0835W	M3*12	LW-4	SR08

C22

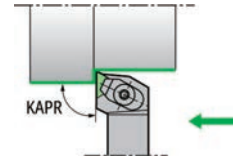
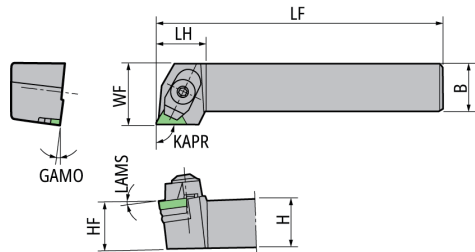

● Diagram shows right-hand tool

EDP	Item Number	Stock	Hand	B mm	GAMO °	H mm	HF mm	KAPR °	LAMS °	LF mm	LH mm	WF mm	Insert Gage	
5538467	C22R-33	●	R	19	6	19	19	91	6	140	25	25	TN..1604..	-
5538483	C22R-34	●	R	19	6	25	25	91	6	160	25	25	TN..1604..	(TN..1607..)
5538491	C22R-44	●	R	25	6	25	25	91	6	160	25	30	TN..1604..	(TN..1607..)
5695630	C22R-45	●	R	25	6	32	32	91	6	160	25	30	TN..1604..	(TN..1607..)
5538475	C22L-33	●	L	19	6	19	19	91	6	140	25	25	TN..1604..	-
5538509	C22L-44	●	L	25	6	25	25	91	6	160	25	30	TN..1604..	(TN..1607..)
5692231	C22L-45	●	L	25	6	32	32	91	6	160	25	30	TN..1604..	(TN..1607..)

Spare Parts

Item Number	Clamp	Shim	Clamp screw	Screw (for Shim)	Wrench (for Clamp screw)	Snap
C22R-33	CC08MS	ATN323	BS0829W	M3*12	LW-4	SR08
C22R-34	CC08MS	ATN323	BS0835W	M3*12	LW-4	SR08
C22R-44	CC08MS	ATN323	BS0835W	M3*12	LW-4	SR08
C22R-45	CC08MS	ATN323	BS0835W	M3*12	LW-4	SR08
C22L-33	CC08MS	ATN323	BS0829W	M3*12	LW-4	SR08
C22L-44	CC08MS	ATN323	BS0835W	M3*12	LW-4	SR08
C22L-45	CC08MS	ATN323	BS0835W	M3*12	LW-4	SR08

C25

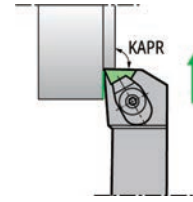
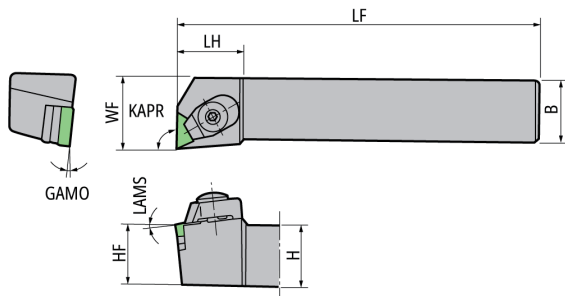

● Diagram shows right-hand tool

EDP	Item Number	Stock	Hand	B mm	GAMO °	H mm	HF mm	KAPR °	LAMS °	LF mm	LH mm	WF mm	Insert Gage
5538566	C25R-33	●	R	19	6	19	19	91	6	140	25	25	TN..1604.. -
5576954	C25R-34	●	R	19	6	25	25	91	6	160	25	25	TN..1604.. (TN..1607..)
5538582	C25R-44	●	R	25	6	25	25	91	6	160	28	30	TN..1604.. (TN..1607..)
5720875	C25R-45	●	R	25	6	32	32	91	6	160	28	30	TN..1604.. (TN..1607..)
5538574	C25L-33	●	L	19	6	19	19	91	6	140	25	25	TN..1604.. -
5538590	C25L-44	●	L	25	6	25	25	91	6	160	28	30	TN..1604.. (TN..1607..)

Spare Parts

Item Number	Clamp	Shim	Clamp screw	Screw (for Shim)	Wrench (for Clamp screw)	Snap
C25R-33	CC08MS	ATN323	BS0829W	M3*12	LW-4	SR08
C25R-34	CC08MS	ATN323	BS0835W	M3*12	LW-4	SR08
C25R-44	CC08MS	ATN323	BS0835W	M3*12	LW-4	SR08
C25R-45	CC08MS	ATN323	BS0835W	M3*12	LW-4	SR08
C25L-33	CC08MS	ATN323	BS0829W	M3*12	LW-4	SR08
C25L-44	CC08MS	ATN323	BS0835W	M3*12	LW-4	SR08

PTLN

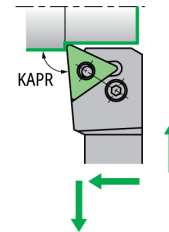
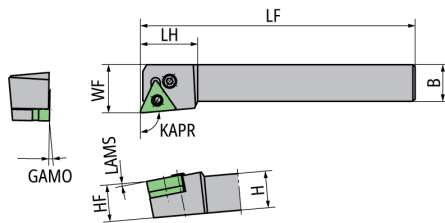

● Diagram shows right-hand tool

EDP	Item Number	Stock	Hand	B mm	GAMO °	H mm	HF mm	KAPR °	LAMS °	LF mm	LH mm	WF mm	Insert Gage
5552336	PTLNR2020L33	●	R	20	6	20	20	95	6	140	25	25	TN..1604..
5552344	PTLNL2020L33	●	L	20	6	20	20	95	6	140	25	25	TN..1604..

Spare Parts

Item Number	Shim	Clamp screw	Wrench (for Clamp screw)	Clamp Pin	Spring
PTLNR2020L33	LST317	LCS3	LW-2.5	LCL3	LSP3
PTLNL2020L33	LST317	LCS3	LW-2.5	LCL3	LSP3

C23

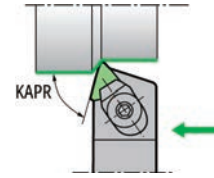
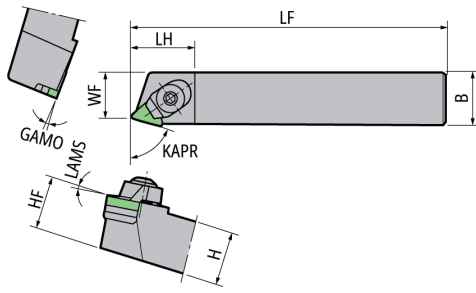

● Diagram shows right-hand tool

EDP	Item Number	Stock	Hand	B mm	GAMO °	H mm	HF mm	KAPR °	LAMS °	LF mm	LH mm	WF mm	Insert Gage
5538541	C23R-33	●	R	19	6	19	19	75	6	140	30	14.5	TN..1604.. -
5576939	C23R-44	●	R	25	6	25	25	75	6	160	30	20.5	TN..1604.. (TN..1607..)
5538558	C23L-44	●	L	25	6	25	25	75	6	160	30	20.5	TN..1604.. (TN..1607..)

Spare Parts

Item Number	Clamp	Shim	Clamp screw	Screw (for Shim)	Wrench (for Clamp screw)	Snap
C23R-33	CC08MS	ATN323	BS0829W	M3*12	LW-4	SR08
C23R-44	CC08MS	ATN323	BS0835W	M3*12	LW-4	SR08
C23L-44	CC08MS	ATN323	BS0835W	M3*12	LW-4	SR08

C24

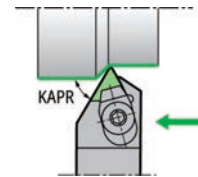
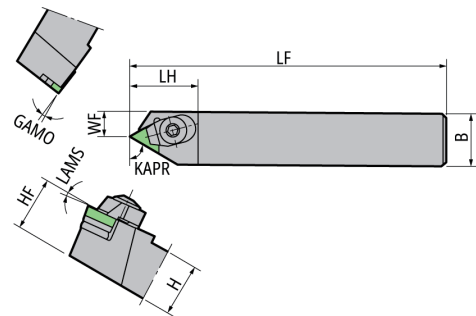

● Diagram shows right-hand tool

EDP	Item Number	Stock	Hand	B mm	GAMO °	H mm	HF mm	KAPR °	LAMS °	LF mm	LH mm	WF mm	Insert Gage
5538517	C24R-34	-	R	19	6	25	25	60	6	160	32	10.5	TN..1604.. (TN..1607..)
5538525	C24R-44	-	R	25	6	25	25	60	6	160	32	16.5	TN..1604.. (TN..1607..)
5538533	C24L-44	-	L	25	6	25	25	60	6	160	32	16.5	TN..1604.. (TN..1607..)

Spare Parts

Item Number	Clamp	Shim	Clamp screw	Screw (for Shim)	Wrench (for Clamp screw)	Snap
C24R-34	CC08MS	ATN323	BS0829W	M3*12	LW-4	SR08
C24R-44	CC08MS	ATN323	BS0835W	M3*12	LW-4	SR08
C24L-44	CC08MS	ATN323	BS0835W	M3*12	LW-4	SR08

TN.. series/Inserts CBN

TNGA

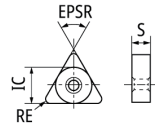

Steel	
Stainless Steel	
Cast Iron	● ● ● ● ○ ○
Non-Ferrous Material	
Heat Resistant Alloy	
Hardened Material	● ● ● ● ● ●
Others (non-metallic)	

Shape	Item Number (ISO)	CECC	EPSR °	IC mm	S mm	AN °	RE mm	D2 mm	Length of edge	No. of edge	S1 mm	CBN											
												B16 PVD	B22	B23	B30	B36	B6K PVD	B40	B52	B5K PVD			
	TNGA160401PHFNX	Up-sharp edge	60	9.525	4.76	-	0.1	-	2.1	6	-												●
	TNGA160401PHS01015	S01015	60	9.525	4.76	-	0.1	-	2.1	6	-												● ● ● ●
	TNGA160401PHS01325	S01325	60	9.525	4.76	-	0.1	-	2.1	6	-												● ● ● ●
	TNGA160401PHS01535	S01535	60	9.525	4.76	-	0.1	-	2.1	6	-												● ● ● ●
	TNGA160402PHFNX	Up-sharp edge	60	9.525	4.76	-	0.2	-	2.2	6	-												● ● ● ●
	TNGA160402PHS01015	S01015	60	9.525	4.76	-	0.2	-	2.2	6	-												● ● ● ●
	TNGA160402PHS01325	S01325	60	9.525	4.76	-	0.2	-	2.2	6	-												● ● ● ●
	TNGA160402PHS01535	S01535	60	9.525	4.76	-	0.2	-	2.2	6	-												● ● ● ●
	TNGA160402PTFNX	Up-sharp edge	60	9.525	4.76	-	0.2	-	2.2	3	-												● ● ● ●
	TNGA160404PHFNX	Up-sharp edge	60	9.525	4.76	-	0.4	-	2	6	-												● ● ● ●
	TNGA160404PHS01015	S01015	60	9.525	4.76	-	0.4	-	2	6	-												● ● ● ●
	TNGA160404PHS01020	S01020	60	9.525	4.76	-	0.4	-	2	6	-												● ● ● ●
	TNGA160404PHS01325	S01325	60	9.525	4.76	-	0.4	-	2	6	-												● ● ● ●
	TNGA160404PHS01535	S01535	60	9.525	4.76	-	0.4	-	2	6	-												● ● ● ●
	TNGA160404PHT01020	T01020	60	9.525	4.76	-	0.4	-	2	6	-												● ● ● ●
	TNGA160404PTFNX	Up-sharp edge	60	9.525	4.76	-	0.4	-	2	3	-												● ● ● ●
	TNGA160408PHFNX	Up-sharp edge	60	9.525	4.76	-	0.8	-	1.7	6	-												● ● ● ●
	TNGA160408PHS01015	S01015	60	9.525	4.76	-	0.8	-	1.7	6	-												● ● ● ●
	TNGA160408PHS01020	S01020	60	9.525	4.76	-	0.8	-	1.7	6	-												● ● ● ●
	TNGA160408PHS01325	S01325	60	9.525	4.76	-	0.8	-	1.7	6	-												● ● ● ●
	TNGA160408PHS01535	S01535	60	9.525	4.76	-	0.8	-	1.7	6	-												● ● ● ●
	TNGA160408PHT01020	T01020	60	9.525	4.76	-	0.8	-	1.7	6	-												● ● ● ●
	TNGA160408PTFNX	Up-sharp edge	60	9.525	4.76	-	0.8	-	1.7	3	-												● ● ● ●
	TNGA160412PHFNX	Up-sharp edge	60	9.525	4.76	-	1.2	-	2.3	6	-												● ● ● ●
	TNGA160412PHS01015	S01015	60	9.525	4.76	-	1.2	-	2.3	6	-												● ● ● ●
	TNGA160412PHS01020	S01020	60	9.525	4.76	-	1.2	-	2.3	6	-												● ● ● ●
	TNGA160412PHS01325	S01325	60	9.525	4.76	-	1.2	-	2.3	6	-												● ● ● ●
	TNGA160412PHS01535	S01535	60	9.525	4.76	-	1.2	-	2.3	6	-												● ● ● ●
	TNGA160412PHT01020	T01020	60	9.525	4.76	-	1.2	-	2.3	6	-												● ● ● ●
	TNGA160412PTFNX	Up-sharp edge	60	9.525	4.76	-	1.2	-	2.3	3	-												● ● ● ●
	TNGA160416PHS01015	S01015	60	9.525	4.76	-	1.6	-	2.1	6	-												● ● ● ●
	TNGA160416PHS01325	S01325	60	9.525	4.76	-	1.6	-	2.1	6	-												● ● ● ●
	TNGA160416PHS01535	S01535	60	9.525	4.76	-	1.6	-	2.1	6	-												● ● ● ●
	TNGA160416PHT01020	T01020	60	9.525	4.76	-	1.6	-	2.1	6	-												● ● ● ●
	TNGA220412PHS01015	S01015	60	12.7	4.76	-	1.2	-	2.3	6	-												● ● ● ●
	TNGA220412PHS01535	S01535	60	12.7	4.76	-	1.2	-	2.3	6	-												● ● ● ●

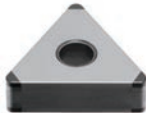

General Turning
Toolholders
U

TNMN

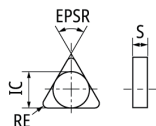

Steel	
Stainless Steel	
Cast Iron	● ● ● ● ○ ○
Non-Ferrous Material	
Heat Resistant Alloy	
Hardened Material	● ● ● ● ● ●
Others (non-metallic)	

Shape	Item Number (ISO)	CECC	EPSR °	IC mm	S mm	AN °	RE mm	D2 mm	Length of edge	No. of edge	S1 mm	CBN											
												B16 PVD	B22	B23	B30	B36	B6K PVD	B40	B52	B5K PVD			
	TNMN110312ST01025	T01025	60	6.35	3.18	-	1.2	-	-	6	-												●
	TNMN160408ST01025	T01025	60	9.525	4.76	-	0.8	-	-	6	-												●
	TNMN160412ST01025	T01025	60	9.525	4.76	-	1.2	-	-	6	-												●
	TNMN160412ST02025	T02025	60	9.525	4.76	-	1.2	-	-	6	-												●



TN.. series/Inserts PCD / Diamond Coating

TNMX

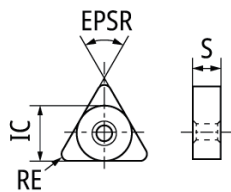

Steel			
Stainless Steel			
Cast Iron			
Non-Ferrous Material	●	●	●
Heat Resistant Alloy			
Hardened Material			
Others (non-metallic)			●

Shape	Item Number (ISO)	CECC	EPSR °	IC mm	S mm	AN °	RE mm	No. of edge	PCD		Diamond Coating
									PD1	PD2	UC1
	TNMX160404PF	Up-sharp edge	60	9.525	4.76	-	0.4	1		●	
	TNMX160408PF	Up-sharp edge	60	9.525	4.76	-	0.8	1		●	

TNMG

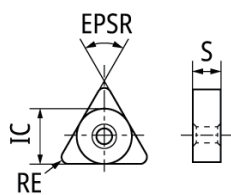

Steel			
Stainless Steel			
Cast Iron			
Non-Ferrous Material	●	●	●
Heat Resistant Alloy			
Hardened Material			
Others (non-metallic)			●

Shape	Item Number (ISO)	CECC	EPSR °	IC mm	S mm	AN °	RE mm	No. of edge	PCD		Diamond Coating
									PD1	PD2	UC1
	TNMG160402FNZP	Up-sharp edge	60	9.525	4.76	-	0.2	6			●
	TNMG160404FNZP	Up-sharp edge	60	9.525	4.76	-	0.4	6			●
	TNMG160408FNZP	Up-sharp edge	60	9.525	4.76	-	0.8	6			●

General Turning
Toolholders

TN.. series/Inserts Carbide

TN..

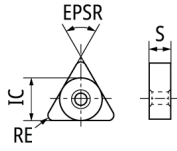

Material	Steel	Stainless Steel	Cast Iron	Non-Ferrous Material	Heat Resistant Alloy	Hardened Material	Others (non-metallic)
Steel	○	●	●	●	●	●	●
Stainless Steel	●	○	○	○	○	○	○
Cast Iron							●
Non-Ferrous Material				○	○		●
Heat Resistant Alloy		●	○	○			
Hardened Material		○	○	○			
Others (non-metallic)							●

Shape	Item Number	CECC	EPSR	IC	S	AN	RE	BS	Carbide												
									PVD	PVD	PVD	PVD	PVD	PVD	PVD	PVD	CVD	CVD	Uncoated		
									ST4	DM4	DT4	QM3	TM4	VM1	ZM3	CP1	CP7	KM1			
	TNNGG160401MFNUL	Up-sharp edge	60	9.525	4.76	-	0.1	-	●	●		●	●								
	TNNGG160402MFNUL	Up-sharp edge	60	9.525	4.76	-	0.2	-	●	●		●	●								
	TNNGG160404MFNUL	Up-sharp edge	60	9.525	4.76	-	0.4	-	●	●		●	●								
	TNNGG160408MFNUL	Up-sharp edge	60	9.525	4.76	-	0.8	-	●	●		●	●								
	TNNGG160402FNZP	Up-sharp edge	60	9.525	4.76	-	0.2	-		●		●	●	●	●						
	TNNGG160404FNZP	Up-sharp edge	60	9.525	4.76	-	0.4	-		●		●	●	●	●						
	TNNGG160408FNZP	Up-sharp edge	60	9.525	4.76	-	0.8	-		●		●	●	●	●						
	TNMG160408G	-	60	9.525	4.76	-	0.8	-													●
	TNMG160412G	-	60	9.525	4.76	-	1.2	-													●
	TNMG160404T00525Z5	T00525	60	9.525	4.76	-	0.4	-		●		●									
	TNMG160408T00525Z5	T00525	60	9.525	4.76	-	0.8	-		●		●									
	TNEG160402FLD1	Up-sharp edge	60	9.525	4.76	-	0.2	-						●							
	TNEG160402FRD1	Up-sharp edge	60	9.525	4.76	-	0.2	-						●							
	TNEG160404FLD1	Up-sharp edge	60	9.525	4.76	-	0.4	-						●							
	TNEG160404FRD1	Up-sharp edge	60	9.525	4.76	-	0.4	-						●							
	TNEG160408FLD1	Up-sharp edge	60	9.525	4.76	-	0.8	-						●							
	TNEG160408FRD1	Up-sharp edge	60	9.525	4.76	-	0.8	-						●							
	TNGG160401FRU2	Up-sharp edge	60	9.525	4.76	-	0.1	-								●	●				
	TNGG160402FRU2	Up-sharp edge	60	9.525	4.76	-	0.2	-		●							●				
	TNGG160404FRU2	Up-sharp edge	60	9.525	4.76	-	0.2	-		●							●				
	TNGG160404FRU2	Up-sharp edge	60	9.525	4.76	-	0.4	-		●							●				
	TNGG160404FRU2	Up-sharp edge	60	9.525	4.76	-	0.4	-		●							●				
	TNGG160408FRU2	Up-sharp edge	60	9.525	4.76	-	0.8	-		●							●				
	TNGG160408FRU2	Up-sharp edge	60	9.525	4.76	-	0.8	-		●						●					
	TNGG160402FRC	Up-sharp edge	60	9.525	4.76	-	0.2	-													●
	TNGG160401FRDA	Up-sharp edge	60	9.525	4.76	-	0.1	-								●	●				

General Turning
Toolholders
U1

WN.. series/Toolholders

WWLN Multi Clamp Toolholders

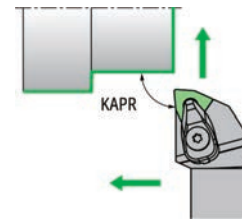
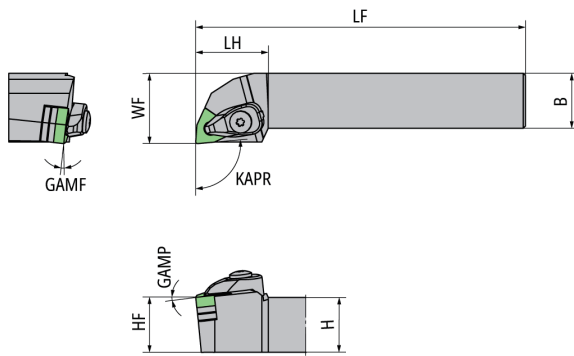

● Diagram shows right-hand tool

EDP	Item Number	Stock	Hand	B mm	GAMF °	GMAP °	H mm	HF mm	KAPR °	LF mm	LH mm	WF mm	Insert Gage
5683016	WWLNR2525M08	●	R	25	6	6	25	25	95	150	33	32	WN..0804.. (WN..0807..)
5683024	WWLNL2525M08	●	L	25	6	6	25	25	95	150	33	32	WN..0804.. (WN..0807..)

Spare Parts

Item Number	Clamp	Shim	Clamp screw	Screw (for Shim)	Wrench (for Clamp screw)	Wrench (for Shim)	Spring
WWLNR2525M08	DC6CN	AWN423-W	AOS-6*30W	FSS15-3.0*12	LLR-T20	LLR-T10	ASGL6-D
WWLNL2525M08	DC6CN	AWN423-W	AOS-6*30W	FSS15-3.0*12	LLR-T20	LLR-T10	ASGL6-D

General Turning
Toolholders

WWLN-2 Multi Clamp Toolholders

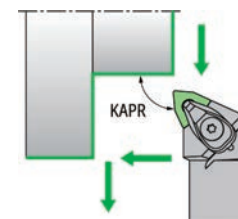
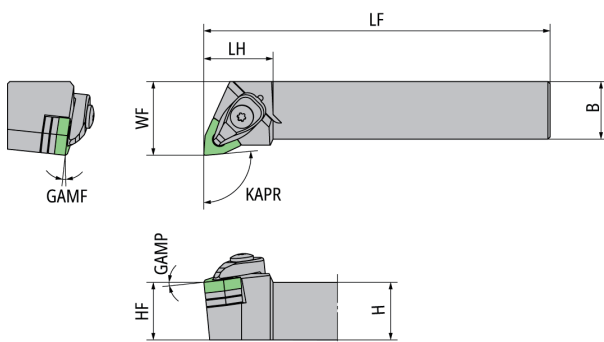

● Diagram shows right-hand tool

EDP	Item Number	Stock	Hand	B mm	GAMF °	GMAP °	H mm	HF mm	KAPR °	LF mm	LH mm	WF mm	Insert Gage
5701578	WWLNR2525M08-2	●	R	25	6	6	25	25	95	150	30	32	WN..0804.. (WN..0807..)
5701586	WWLNL2525M08-2	●	L	25	6	6	25	25	95	150	30	32	WN..0804.. (WN..0807..)

Spare Parts

Item Number	Clamp	Shim	Clamp screw	Screw (for Shim)	Wrench (for Clamp screw)	Wrench (for Shim)	Spring
WWLNR2525M08-2	DC6CN	AWN423-W	AOS-6*30W	FSS18-3.0*14	LLR-T20	LLR-T10	ASGL6-D
WWLNL2525M08-2	DC6CN	AWN423-W	AOS-6*30W	FSS18-3.0*14	LLR-T20	LLR-T10	ASGL6-D

RN.. series/Toolholders

CRDN

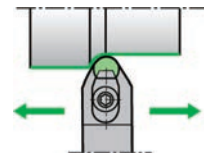
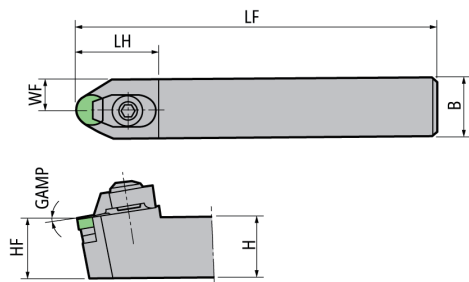

EDP	Item Number	Stock	Hand	B mm	GMAP °	H mm	HF mm	LF mm	LH mm	WF mm	Insert Gage
5700323	CRDNN2525M12	●	N	25	6	25	25	150	34	12.5	RN..1204.. (RN..1207..)
5700331	CRDNN3225P12	●	N	25	6	32	32	170	34	12.5	RN..1204.. (RN..1207..)

Spare Parts

Item Number	Clamp	Shim	Clamp screw	Screw (for Shim)	Wrench (for Clamp screw)	Snap
CRDNN2525M12	CC08M	ARN42	BS0835W	M3*12	LW-4	SR08
CRDNN3225P12	CC08M	ARN42	BS0835W	M3*12	LW-4	SR08

CRGN

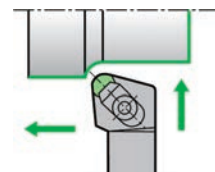
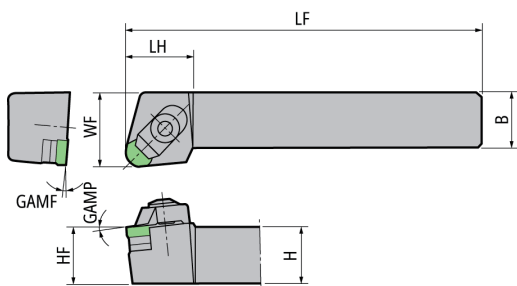

● Diagram shows right-hand tool

EDP	Item Number	Stock	Hand	B mm	GAMF °	GMAP °	H mm	HF mm	LF mm	LH mm	WF mm	Insert Gage
5829395	CRGNR3225P12	●	R	25	6	6	32	32	170	30	32	RN..1204.. (RN..1207..)

Spare Parts

Item Number	Clamp	Shim	Clamp screw	Screw (for Shim)	Wrench (for Clamp screw)	Snap
CRGNR3225P12	CC08M	ARN42	BS0835W	M3*12	LW-4	SR08

C54

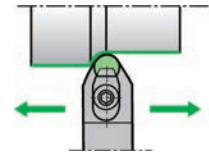
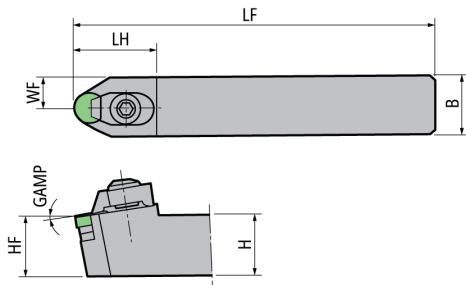

EDP	Item Number	Stock	Hand	B mm	GMAP °	H mm	HF mm	LF mm	LH mm	WF mm	Insert Gage
5538392	C54M-44	●	N	25	8	25	25	160	33	12.5	RN..1204.. (RN..1207..)

Spare Parts

Item Number	Clamp	Shim	Clamp screw	Screw (for Shim)	Wrench (for Clamp screw)	Snap
C54M-44	CC08M	ARN42	BS0835W	M3*12	LW-4	SR08

C55

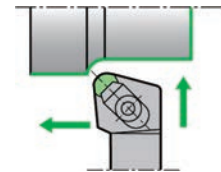
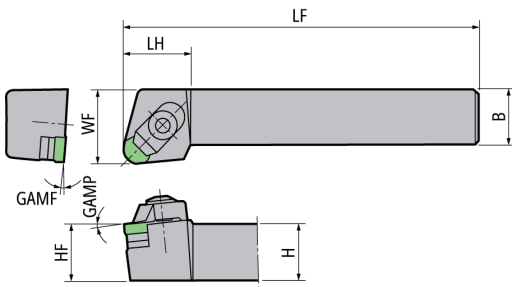

● Diagram shows right-hand tool

EDP	Item Number	Stock	Hand	B mm	GAMF °	GMAP °	H mm	HF mm	LF mm	LH mm	WF mm	Insert Gage
5538400	C55R-33	●	R	19	6	6	19	19	140	30	28	RN..1204.. -
5573027	C55R-44	●	R	25	6	6	25	25	160	30	30	RN..1204.. (RN..1207..)
5768221	C55R-45	●	R	25	6	6	32	32	160	30	30	RN..1204.. (RN..1207..)
5538418	C55L-44	●	L	25	6	6	25	25	160	30	30	RN..1204.. (RN..1207..)

Spare Parts



Item Number	Clamp	Shim	Clamp screw	Screw (for Shim)	Wrench (for Clamp screw)	Snap
C55R-33	CC08M	ARN42	BS0829W	M3*12	LW-4	SR08
C55R-44	CC08M	ARN42	BS0835W	M3*12	LW-4	SR08
C55R-45	CC08M	ARN42	BS0835W	M3*12	LW-4	SR08
C55L-44	CC08M	ARN42	BS0835W	M3*12	LW-4	SR08

RN.. series/Inserts CBN

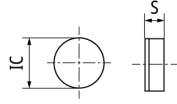
RN.N



Steel	
Stainless Steel	
Cast Iron	● ● ● ● ○ ○
Non-Ferrous Material	
Heat Resistant Alloy	
Hardened Material	● ● ● ● ●
Others (non-metallic)	

Shape	Item Number (ISO)	CECC	EPSR °	IC mm	S mm	AN °	RE mm	D2 mm	Length of edge	No. of edge	S1 mm	CBN									
												B16 PVD	B22	B23	B30	B36	B6K PVD	B40	B52	B5K PVD	
	RNMN120300ST01025	T01025	-	12.7	3.18	-	-	-	-	-	-	●									
	RNMN120400ST01025	T01025	-	12.7	4.76	-	-	-	-	-	-	●									
	RNGN120400S	Z01015	-	12.7	4.76	-	-	-	-	-	-	●									

General Turning
Toolholders

RCGX/RPGX.. series/Toolholders

CRDC

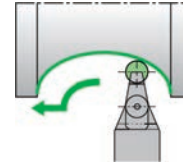
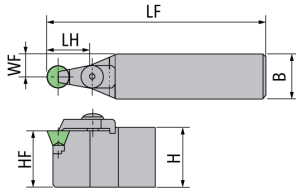

EDP	Item Number	Stock	Hand	B mm	H mm	HF mm	LF mm	LH mm	Insert Gage
5911557	CRDCN3225P06	●	N	25	32	32	170	20	RCGX0607../RPGX0607..
5829528	CRDCN3225P09	●	N	25	32	32	170	20	RCGX0907../RPGX0907..
5829510	CRDCN3225P12	●	N	25	32	32	170	25	RCGX1207../RPGX1207..

Spare Parts

Item Number	Clamp	Shim	Clamp screw	Wrench (for Clamp screw)	Washer	Spring pin
CRDCN3225P06	HC35KR-4099	HARCGX06	BS0520	LW-3	WS-5	-
CRDCN3225P09	HC35KR-6075	HARCGX0908V	BS0625	LW-4	WS-6	2*8AW
CRDCN3225P12	HC35KR-6076	HARCGX1208V	BS0625	LW-4	WS-6	2.5*8AW

SCRUM DUO BLADE

RCGX/RPGX.. series/Straight style toolholder

GTWPR

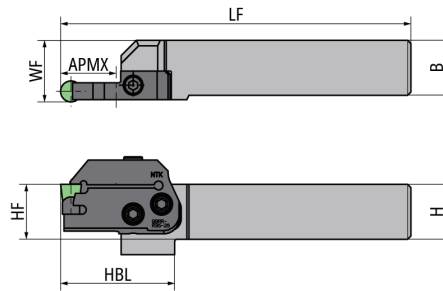

● Diagram shows right-hand tool

Blade number	Stock	Insert	Dimensions(mm)			Dimensions(mm)				
			APMX	Holder	LF	HBL	WF	H	B	HF
GBRR-R23-19	●	RCGX0604 RPGX0604	19	GTWPR2020-H	130.1	51.1	23	20	20	20
				GTWPR2525-H	155.1	47.1	28	25	25	25
				GTWPR3232-H	175.1	-	35	32	32	32
GBRR-R35-25	●	RCGX0907 RPGX0907	25.4	GTWPR2020-H	135.2	56.2	23	20	20	20
				GTWPR2525-H	160.2	52.2	28	25	25	25
				GTWPR3232-H	180.2	-	35	32	32	32
GBRR-R45-28	●	RCGX1207 RPGX1207	28.5	GTWPR2020-H	137.7	58.7	23	20	20	20
				GTWPR2525-H	162.7	54.7	28	25	25	25
				GTWPR3232-H	182.7	-	35	32	32	32

GTWPL

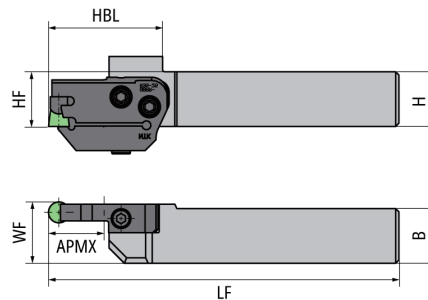

● Diagram shows left-hand tool

Blade number	Stock	Insert	Dimensions(mm)			Dimensions(mm)				
			APMX	Holder	LF	HBL	WF	H	B	HF
GBRL-R23-19	●	RCGX0604 RPGX0604	19	GTWPL2020-H	130.1	51.1	23	20	20	20
				GTWPL2525-H	155.1	47.1	28	25	25	25
				GTWPL3232-H	175.1	-	35	32	32	32
GBRL-R35-25	●	RCGX0907 RPGX0907	25.4	GTWPL2020-H	135.2	56.2	23	20	20	20
				GTWPL2525-H	160.2	52.2	28	25	25	25
				GTWPL3232-H	180.2	-	35	32	32	32
GBRL-R45-28	●	RCGX1207 RPGX1207	28.5	GTWPL2020-H	137.7	58.7	23	20	20	20
				GTWPL2525-H	162.7	54.7	28	25	25	25
				GTWPL3232-H	182.7	-	35	32	32	32

Spare Parts

Blade Number	Clamp screw
GBRR-R23-19	CS0515
GBRR-R35-25	CS0515
GBRR-R45-28	CS0615
GBRL-R23-19	CS0515
GBRL-R35-25	CS0515
GBRL-R45-28	CS0615

RCGX/RPGX.. series/L-style toolholder

GKWPR

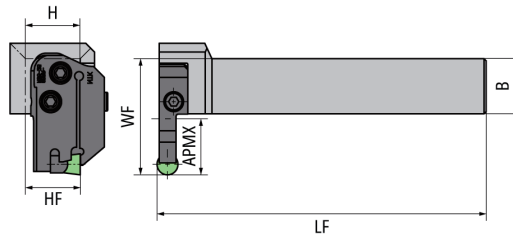

● Diagram shows right-hand tool

Blade number	Stock	Insert	Dimensions(mm)			Dimensions(mm)				
			APMX	Holder	LF	HBL	WF	H	B	HF
GBRL-R23-19	●	RCGX0604 RPGX0604	19	GKWPR2020-H	125	-	42.6	20	20	20
				GKWPR2525-H	150	-	47.6	25	25	25
				GKWPR3232-H	170	-	54.6	32	32	32
GBRL-R35-25	●	RCGX0907 RPGX0907	25.4	GKWPR2020-H	125	-	47.7	20	20	20
				GKWPR2525-H	150	-	52.7	25	25	25
				GKWPR3232-H	170	-	59.7	32	32	32
GBRL-R45-28	●	RCGX1207 RPGX1207	28.5	GKWPR2020-H	125	-	50.2	20	20	20
				GKWPR2525-H	150	-	55.2	25	25	25
				GKWPR3232-H	170	-	62.2	32	32	32

GKWPL

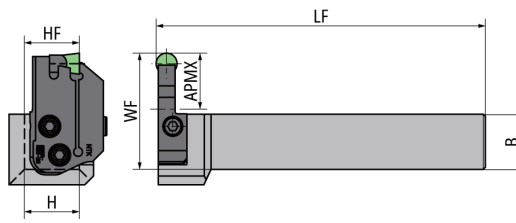

● Diagram shows left-hand tool

Blade number	Stock	Insert	Dimensions(mm)			Dimensions(mm)				
			APMX	Holder	LF	HBL	WF	H	B	HF
GBRR-R23-19	●	RCGX0604 RPGX0604	19	GKWPL2020-H	125	-	42.6	20	20	20
				GKWPL2525-H	150	-	47.6	25	25	25
				GKWPL3232-H	170	-	54.6	32	32	32
GBRR-R35-25	●	RCGX0907 RPGX0907	25.4	GKWPL2020-H	125	-	47.7	20	20	20
				GKWPL2525-H	150	-	52.7	25	25	25
				GKWPL3232-H	170	-	59.7	32	32	32
GBRR-R45-28	●	RCGX1207 RPGX1207	28.5	GKWPL2020-H	125	-	50.2	20	20	20
				GKWPL2525-H	150	-	55.2	25	25	25
				GKWPL3232-H	170	-	62.2	32	32	32

Spare Parts

Blade Number	Clamp screw
GBRL-R23-19	CS0515
GBRL-R35-25	CS0515
GBRL-R45-28	CS0615
GBRR-R23-19	CS0515
GBRR-R35-25	CS0515
GBRR-R45-28	CS0615

SCRUM DUO BLADE

RCGX/RPGX.. series/Toolholders

GTWP-H Straight style toolholder

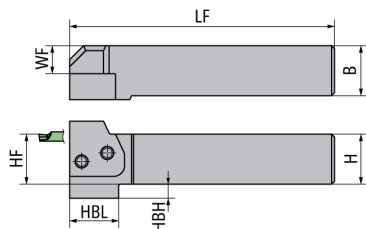

● Diagram shows right-hand tool

EDP	Item Number	Stock	Hand	B mm	H mm	HBH mm	HBL mm	HF mm	LF mm	Insert Gage
5923784	GTWPR2020-H	●	R	20	20	8	28.5	20	107.5	GWPFM../VGW../RCGX../RPGX..
5923800	GTWPR2525-H	●	R	25	25	7	24.5	25	132.5	GWPFM../VGW../RCGX../RPGX..
5963657	GTWPR3232-H	●	R	32	32	-	-	32	152.5	GWPFM../VGW../RCGX../RPGX..
5923792	GTWPL2020-H	●	L	20	20	8	28.5	20	107.5	GWPFM../VGW../RCGX../RPGX..
5923818	GTWPL2525-H	●	L	25	25	7	24.5	25	132.5	GWPFM../VGW../RCGX../RPGX..
5963673	GTWPL3232-H	●	L	32	32	-	-	32	152.5	GWPFM../VGW../RCGX../RPGX..

Spare Parts

Item Number	Blade	Mounting screw	Wrench (for Mounting screw)
GTWPR2020-H	GBWPF..../GBRR-R../GBVR-VGW../GBI-VGW.R../GBO-VGW.R..	FSI28-6.0*18	LW-4
GTWPR2525-H	GBWPF..../GBRR-R../GBVR-VGW../GBI-VGW.R../GBO-VGW.R..	FSI28-6.0*18	LW-4
GTWPR3232-H	GBWPF..../GBRR-R../GBVR-VGW../GBI-VGW.R../GBO-VGW.R..	FSI28-6.0*18	LW-4
GTWPL2020-H	GBWPF..../GBRL-R../GBVL-VGW../GBI-VGW.L../GBO-VGW.L..	FSI28-6.0*18	LW-4
GTWPL2525-H	GBWPF..../GBRL-R../GBVL-VGW../GBI-VGW.L../GBO-VGW.L..	FSI28-6.0*18	LW-4
GTWPL3232-H	GBWPF..../GBRL-R../GBVL-VGW../GBI-VGW.L../GBO-VGW.L..	FSI28-6.0*18	LW-4

General Turning
Toolholders

GKWP-H L-style toolholder

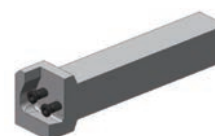
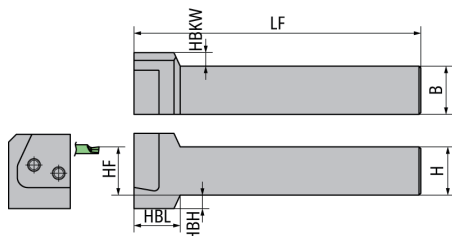

● Diagram shows right-hand tool

EDP	Item Number	Stock	Hand	B mm	H mm	HBH mm	HBKW mm	HBL mm	HF mm	LF mm	Insert Gage
5923826	GKWPR2020-H	●	R	20	20	8	12	24	20	124	GWPFM../VGW../RCGX../RPGX..
5923842	GKWPR2525-H	●	R	25	25	7	7	24	25	149	GWPFM../VGW../RCGX../RPGX..
5963681	GKWPR3232-H	●	R	32	32	-	-	-	32	169	GWPFM../VGW../RCGX../RPGX..
5923834	GKWPL2020-H	●	L	20	20	8	12	24	20	124	GWPFM../VGW../RCGX../RPGX..
5923859	GKWPL2525-H	●	L	25	25	7	7	24	25	149	GWPFM../VGW../RCGX../RPGX..
5963699	GKWPL3232-H	●	L	32	32	-	-	-	32	169	GWPFM../VGW../RCGX../RPGX..

Spare Parts

Item Number	Blade	Mounting screw	Wrench (for Mounting screw)
GKWPR2020-H	GBWPF..../GBRL-R../GBVL-VGW../GBI-VGW.L../GBO-VGW.L..	FSI28-6.0*18	LW-4
GKWPR2525-H	GBWPF..../GBRL-R../GBVL-VGW../GBI-VGW.L../GBO-VGW.L..	FSI28-6.0*18	LW-4
GKWPR3232-H	GBWPF..../GBRL-R../GBVL-VGW../GBI-VGW.L../GBO-VGW.L..	FSI28-6.0*18	LW-4
GKWPL2020-H	GBWPF..../GBRR-R../GBVR-VGW../GBI-VGW.R../GBO-VGW.R..	FSI28-6.0*18	LW-4
GKWPL2525-H	GBWPF..../GBRR-R../GBVR-VGW../GBI-VGW.R../GBO-VGW.R..	FSI28-6.0*18	LW-4
GKWPL3232-H	GBWPF..../GBRR-R../GBVR-VGW../GBI-VGW.R../GBO-VGW.R..	FSI28-6.0*18	LW-4

TSN.. series/Toolholders

HN..ATS

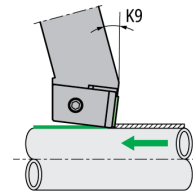
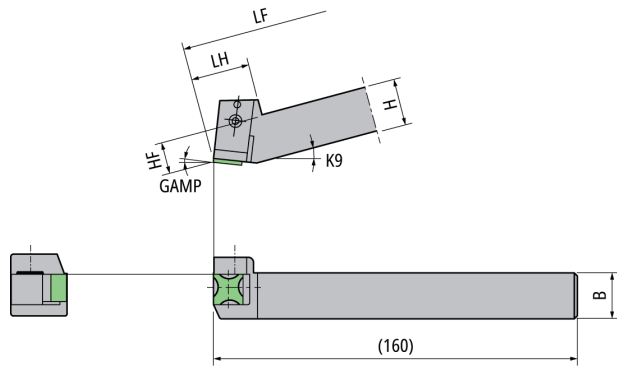

● Diagram shows left-hand(60) tool

EDP	Item Number	Stock	Hand	B mm	GMAP °	H mm	HF mm	K9 °	LF mm	LH mm	Insert Gage	
-	HN59ATS-33E	-	R	19	7	19	12.5	15	160	26	TSN1207..	TSN45..
5350574	HN59ATS-44E	●	R	25	7	25	18.5	15	160	26	TSN1207..	TSN45..
-	HN59ATS-44E-5	-	R	25	7	25	18.5	15	160	26	TSN1507..	TSN55..
-	HN60ATS-33E	-	L	19	7	19	12.5	15	160	26	TSN1207..	TSN45..
-	HN60ATS-44E	-	L	25	7	25	18.5	15	160	26	TSN1207..	TSN45..
-	HN60ATS-44E-5	-	L	25	7	25	18.5	15	160	26	TSN1507..	TSN55..

Spare Parts

Item Number	Clamp	Shim	Shim	Clamp screw	Screw (for Shim)	Screw (for Shim)	Wrench (for Clamp screw)
HN59ATS-33E	HC59TS-4	ASN423	AZT659D	WS0620	M3*5.5	M3*8	LW-3
HN59ATS-44E	HC59TS-4	ASN423	AZT659D	WS0620	M3*5.5	M3*8	LW-3
HN59ATS-44E-5	HC59TS-4	ASN522	HAZT1255A	WS0620	M3*8	M4*5.5	LW-3
HN60ATS-33E	HC60TS-4	ASN423	AZT659D	WS0620	M3*5.5	M3*8	LW-3
HN60ATS-44E	HC60TS-4	ASN423	AZT659D	WS0620	M3*5.5	M3*8	LW-3
HN60ATS-44E-5	HC60TS-4	ASN522	HAZT1255A	WS0620	M3*8	M4*5.5	LW-3

HN..BTS

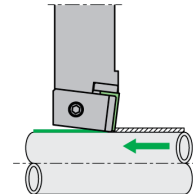
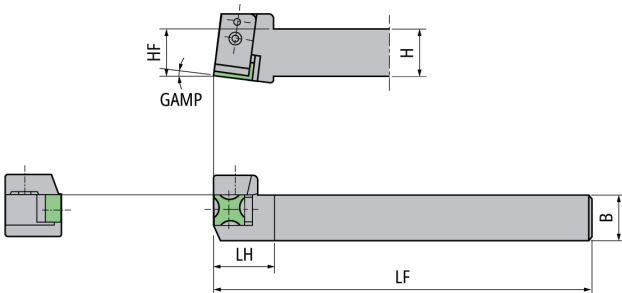

● Diagram shows left-hand(60) tool

EDP	Item Number	Stock	Hand	B mm	GMAP °	H mm	HF mm	LF mm	LH mm	Insert Gage	
-	HN59BTS-44E	-	R	25	7	25	25	160	25	TSN1207..	TSN45..
-	HN59BTS-44E-5	-	R	25	7	25	25	160	25	TSN1507..	TSN55..
-	HN60BTS-33E	-	L	19	7	19	19	160	25	TSN1207..	TSN45..
-	HN60BTS-44E	-	L	25	7	25	25	160	25	TSN1207..	TSN45..
-	HN60BTS-44E-5	-	L	25	7	25	25	160	25	TSN1507..	TSN55..

Spare Parts

Item Number	Clamp	Shim	Shim	Clamp screw	Screw (for Shim)	Screw (for Shim)	Wrench (for Clamp screw)
HN59BTS-44E	HC59TS-4	ASN423	AZT659D	WS0620	M3*5.5	M3*8	LW-3
HN59BTS-44E-5	HC59TS-4	ASN522	HAZT1255A	WS0620	M3*8	M4*5.5	LW-3
HN60BTS-33E	HC60TS-4	ASN423	AZT659D	WS0620	M3*5.5	M3*8	LW-3
HN60BTS-44E	HC60TS-4	ASN423	AZT659D	WS0620	M3*5.5	M3*8	LW-3
HN60BTS-44E-5	HC60TS-4	ASN522	HAZT1255A	WS0620	M3*8	M4*5.5	LW-3

TSN.. series/Inserts Ceramics

TSN

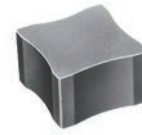
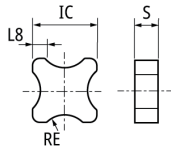

Item Number	IC	RE	S	L8	Alumina Ceramics	
	mm	mm	mm	mm	CX3	HC1
TSN1207-10	12.7	10	7.94	2.1	■	●
TSN1207-12	12.7	12	7.94	2.1	■	●
TSN1207-14	12.7	14	7.94	2.1	■	●
TSN1207-16	12.7	16	7.94	2.1	■	●
TSN1207-18	12.7	18	7.94	2.1	■	●
TSN1207-20	12.7	20	7.94	2.1	■	●
TSN1207-25	12.7	25	7.94	2.1	■	●
TSN1207-30	12.7	30	7.94	2.1	■	●
TSN1207-35	12.7	35	7.94	2.1	■	●
TSN1207-40	12.7	45	7.94	2.1	■	●
TSN1207-50	12.7	50	7.94	2.1	■	●
TSN1507-20	15.875	20	7.94	3.2	■	●
TSN1507-25	15.875	25	7.94	3.2	■	●
TSN1507-30	15.875	30	7.94	3.2	■	●
TSN1507-35	15.875	35	7.94	3.2	■	●
TSN1507-40	15.875	40	7.94	3.2	■	●
TSN1507-45	15.875	45	7.94	3.2	■	●