

# Rotating Tools



series

\* Recommend using torque wrench @35lbs (4Nm)



A.R.+5°  
R.R.-7°30'

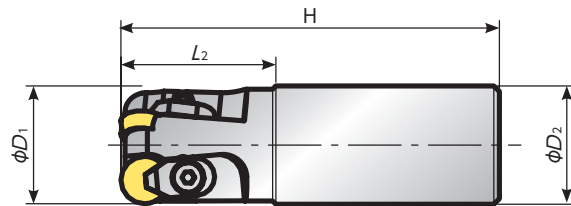

● Inch size cutters

Item Number	Stock		Dimensions (inch)				Clamp	Clamp Screw	Weight (lbs)	Insert
			$\phi D_1$	$D_2$	$H$	$L_2$				
RPIW0625E0625R02	●	2	.625	.625	3.160	1.250	C-423978	S-3-48*1/4SHCS	0.2	RPG 21.5
RPIW075E075R02	●	2	.750	.750	3.270	1.220	AMS-3	AOB-3S	0.4	RPG 21.5
RPIW100E100R03	●	3	1.000	1.000	3.270	1.000	AMS-4	AOB-4S	0.6	RPG 32
RPIW125E125R03	●	3	1.250	1.250	4.000	1.640	AMS-5T	AOB-5S-T25	1.1	RPG 43
RPIW150E150R03	●	3	1.500	1.500	4.000	1.830			1.6	

● Metric size cutters

Item Number	Stock		Dimensions (mm)				Clamp	Clamp Screw	Weight (kg)	Insert
			$\phi D_1$	$D_2$	$H$	$L_2$				
JRPMW032E250R03	○	3	32	25	120	AMS-5T	AOB-5S-T25	0.4	RPG 43	
JRPMW032E320R03	○		32	32				0.6		
JRPMW040E320R03	○		40	32				0.7		



A.R.+5°  
R.R.-2°30' ~ -5°

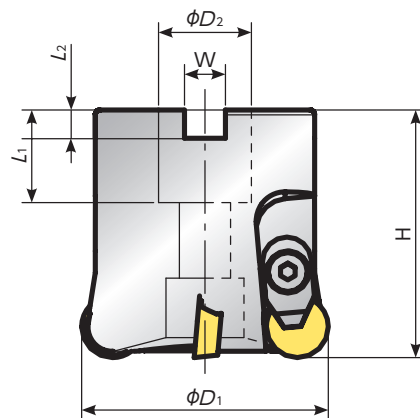

● Inch size cutters

Item Number	Stock		Dimensions (inch)						Shim	Shim Screw	Clamp	Clamp Screw	A.R.	R.R.	Weight (lbs)	Insert
			$\phi D_1$	$H$	$D_2$	$W$	$L_1$	$L_2$								
RPIW200S075R04	●	4	2.00	2.00	.750	.32	.75	.22	ARP42A	M3 * 8	AMS-5T	AOB-5S-T25	+5°	+5°	0.9	RPG 43
RPIW300S100R05	●	5	3.00	2.00	1.000	.38	.75	.22					+5°	+5°	2.0	
RPIW400S125R06	●	6	4.00	2.00	1.250	.50	.82	.30					+5°	+5°	4.2	

● Metric size cutters

Item Number	Stock		Dimensions (mm)						Shim	Shim Screw	Clamp	Clamp Screw	A.R.	R.R.	Weight (kg)	Insert
			$\phi D_1$	$H$	$D_2$	$W$	$L_1$	$L_2$								
JRPMW050S220R04	○	4	50	50	22	10.4	20	6.3	ARP42A	M3 * 8	AMS-5T	AOB-5S-T25	+5°	+5°	0.4	RPG 43
JRPMW063S220R04	○	4	63	50	22	10.4	20	6.3					+5°	+5°	0.6	
JRPMW080S254R05	○	5	80	50	25.4	9.5	25	6.0					+5°	+2°30'	0.9	

● Inserts

(inch)	IC	T	(inch)	IC	T
RPG 21.5	1/4	3/32	RPG 43	1/2	3/16
RPG 32	3/8	1/8			

● : 1st Choice   ● : 2nd choice

	Steel	P							
	Stainless Steel	M							
	Cast Iron	K	●	●	●	●	●	●	●
	Non-Ferrous Material	N							
	Heat Resistant Alloy	S	●	●	●	●	●	●	●
	Hardened Material	H						●	●
Item Number	ISO Item Number	IC	Ceramics						
			SiAlON				Whisker	Alumina - TiC	
			SX7	SX3	SX9	SX5	WA1	HC7	
RPG 21.5 E02	RPGN 060200 E004	1/4	●						
RPG 21.5 T0220	RPGN 060200 T00520	1/4		●	●	●	●	●	
RPG 21.5 T0320	RPGN 060200 T00820	1/4	●						
RPG 21.5 T0420	RPGN 060200 T01020	1/4						●	
RPG 32 E02	RPGN 090300 E004	3/8	●						
RPG 32 T0220	RPGN 090300 T00520	3/8		●	●			●	
RPG 32 T0320	RPGN 090300 T00820	3/8	●						
RPG 32 T0420	RPGN 090300 T01020	3/8						●	
RPG 43 E01	RPGN 120400 E002	1/2				●			
RPG 43 E02	RPGN 120400 E004	1/2	●						
RPG 43 T0220	RPGN 120400 T00520	1/2		●	●		●	●	
RPG 43 T0225	RPGN 120400 T00525	1/2			○				
RPG 43 T0320	RPGN 120400 T00820	1/2	●						
RPG 43 T0420	RPGN 120400 T01020	1/2				●	●	●	●
RPG 43 Z0620	RPGN 120400 Z01520	1/2						●	
RPG 43 Z0825	RPGN 120400 Z02025	1/2							●

● Recommend Cutting Conditions

Work Material	Grade	Dry	Wet	Cutting Speed (SFM)									Feed (IPT)							Depth of Cut (inch)	
				200	700	1200	1700	2200	2700	3200	3700	.002	.003	.004	.005	.006	.007				
S Heat Resistant Alloys	SX7	●																		~.150	
	SX3	●																			~.150
	SX9	●																			~.150
H Hardened Steel	WA1	●	○																		~.150
	HRC 45-55 HC7	●	○																		~.150
	HRC 55-65 WA1	●	○																		~.150
	HRC 55-65 HC7	●	○																		~.150

Rotating Tools



**\* Recommend using torque wrench @35lbs (4Nm)**

A.R.-5°  
R.R.-10°

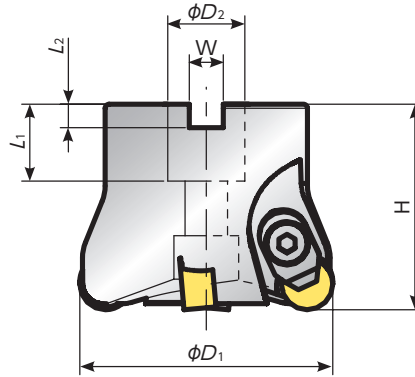

● Inch size cutters

Item Number	Stock	✳	Dimensions (inch)						Clamp	Clamp Screw	Weight (lbs)	Insert
			$\phi D_1$	H	$\phi D_2$	W	L <sub>1</sub>	L <sub>2</sub>				
RNIW200S075R04-43	●	4	2.00	2.00	.750	.32	.75	.22	AMS-6T	AOB-6S-T30	1.0	RNG 43
RNIW200S075R03	●	3	2.00	2.00	.750	.32	.75	.22			1.0	
RNIW250S075R04	●	4	2.50	2.00	.750	.32	.75	.22			1.3	RNG 45
RNIW300S100R05	●	5	3.00	2.00	1.000	.38	.75	.22			1.6	
RNIW400S125R06	●	6	4.00	2.00	1.250	.51	.82	.30			4.2	

● Metric size cutters

Item Number	Stock	✳	Dimensions (mm)						Clamp	Clamp Screw	Weight (kg)	Insert
			$\phi D_1$	H	$\phi D_2$	W	L <sub>1</sub>	L <sub>2</sub>				
JRNMW050S220R03	○	3	50	50	22	10.4	20	6.3	AMS-6T	AOB-6S-T30	0.4	RNG 45
JRNMW063S220R04	○	4	63	50	22	10.4	20	6.3			0.6	
JRNMW080S254R05	○	5	80	50	25.4	9.5	25	6.0			0.9	

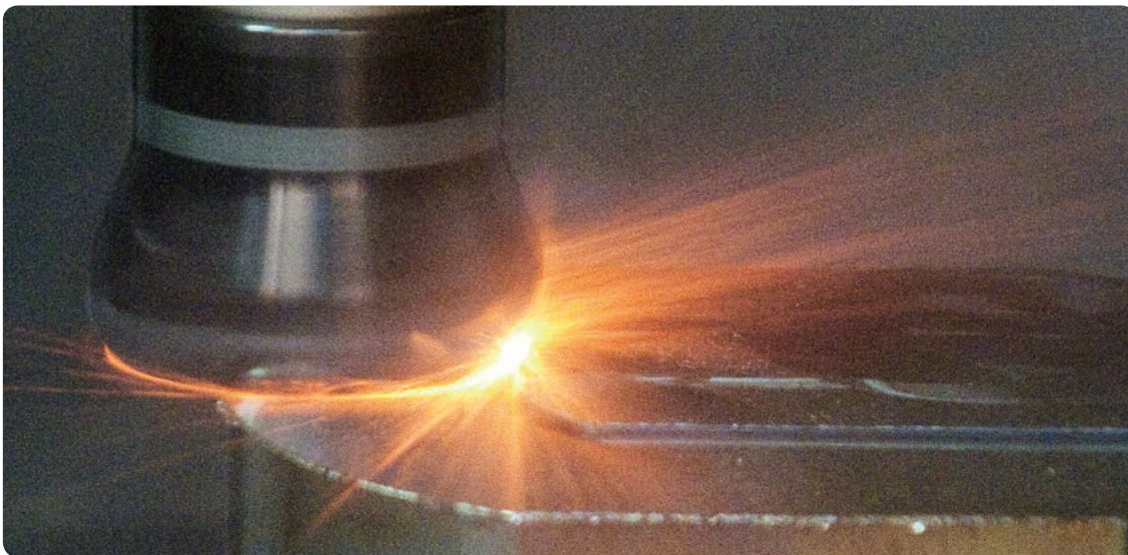

● Inserts

	(inch)	IC	T	(inch)	IC	T
	RNG 43	1/2	3/16	RNG 45	1/2	5/16

● : 1st Choice ● : 2nd choice

	Steel	P									
	Stainless Steel	M									
	Cast Iron	K	●	●	●	●	●	●	●	●	●
	Non-Ferrous Material	N									
	Heat Resistant Alloy	S	●	●	●	●	●	●	●	●	●
	Hardened Material	H						●			●
Item Number	ISO Item Number	IC	Ceramics								
			SIALON				Whisker	Silicon Nitride		Alumina - TiC	
			SX7	SX3	SX9	SX5	WA1	SX6	SP9	HC7	
RNG 43 E01	RNGN 120400 E002	1/2			●						
RNG 43 E02	RNGN 120400 E004	1/2	●	●							
RNG 43 T0220	RNGN 120400 T00520	1/2		●	●	●	●	●			
RNG 43 T0225	RNGN 120400 T00525	1/2			○			○			
RNG 43 T0320	RNGN 120400 T00820	1/2	●								
RNG 43 T0420	RNGN 120400 T01020	1/2			●			●		●	●
RNG 43 T0820	RNGN 120400 T02020	1/2							●		
RNG 43 T0825	RNGN 120400 T02025	1/2			○						
RNG 43 Z0825	RNGN 120400 Z02025	1/2									●
RNG 45 E01	RNGN 120700 E002	1/2			●				●		
RNG 45 E02	RNGN 120700 E004	1/2	●	●							
RNG 45 T0220	RNGN 120700 T00520	1/2		●	●	●	●	●			
RNG 45 T0225	RNGN 120700 T00525	1/2			○			○			
RNG 45 T0320	RNGN 120700 T00820	1/2	●								
RNG 45 T0420	RNGN 120700 T01020	1/2			●		●	●			●
RNG 45 Z0620	RNGN 120700 Z01520	1/2							●		
RNG 45 Z0825	RNGN 120700 Z02025	1/2									●

● Recommend Cutting Conditions

Work Material	Grade	Dry	Wet	Cutting Speed (SFM)								Feed (IPT)						Depth of Cut (inch)	
				200	700	1200	1700	2200	2700	3200	3700	.002	.003	.004	.005	.006	.007		
S Heat Resistant Alloys	SX7	●																	~.150
	SX3	●																	~.150
	SX9	●																	~.150
H Hardened Steel	WA1	●	○																~.150
	HRC 45-55 HC7	●	○																~.150
	HRC 55-65 WA1	●	○																~.150
	HRC 55-65 HC7	●	○																~.150

● : Stock  
 ● : Stock (Newly added)  
 ■ □ □ □ : While stocks last  
 R L : Stock (Right / Left-hand only)  
 R L : Stock (Right / Left-hand only, Newly added)  
 ○ : 1-2 week delivery  
 ○ : 1-2 week delivery (Newly added)  
 ● : Coolant through  
 (R/L) : 1-2 week delivery (Right / Left-hand only)  
 (R/L) : 1-2 week delivery (Right / Left-hand only, Newly added)